

Updatemydynaco

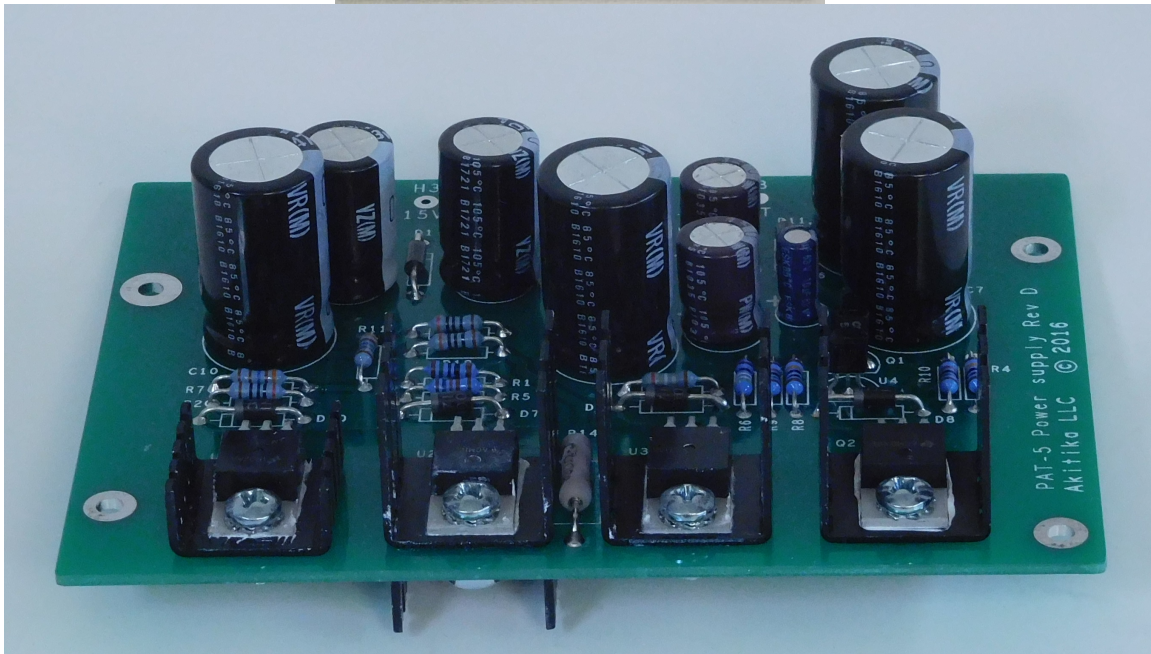

Dynaco PAT-5 Preamp Replacement Power Supply (PAT5PWR) ASSEMBLY MANUAL Rev E Hardware

© 2018 Akitika LLC
All rights reserved
Revision 3p09 December 7, 2024

Table of Contents

Table of Contents	2
Table of Figures	3
Section 1: About This Manual	4
Who Should Attempt this Project?	4
Tools you'll need	4
Helpful Tools	4
Project Overview	4
Important Safety Notes	5
About Components	5
Recommended Solder	5
Warranty	5
Section 2: Kit Building Hints.....	6
Section 3: Building the Power Supply	7
Component Order.....	8
Install the Resistors	8
Install the diodes	8
Install R14.....	9
Install the TO-220 Regulators, Power Transistors and Heatsinks	9
Assembly Hint	10
Install the Small Non-polar Capacitors.....	11
Install Shunt Regulator and Small Transistor	11
Install the Electrolytic (polarized) Capacitors	11
Check your work.....	12
Checking the preamp and old power supply	12
If your voltages were out of tolerance	13
Removing the Old Power Supply	14
Installing the New Power Supply	16
Testing the power supply in place	17
Final Re-Assembly.....	18
About the Design	18
Schematic	20

Table of Figures

Figure 1-Assembled PAT-5 Power Supply. Note that U2, U3, and Q2 get tall heatsinks .	6
Figure 2-Empty the power supply components into a soup bowl.....	7
Figure 3-Silk screen shows power supply component locations	7
Figure 4-Regulator and Heat Sink Assembly Detail.....	9
Figure 5-Applying thermal compound.....	10
Figure 6-Heatsink Installation.....	10
Figure 7-Line up the bottom heatsink to not touch the nearby trace	11
Figure 8-Remove hardware that holds power supply bracket to chassis floor	14
Figure 9-Remove these 2 screws and 2 screws on the opposite side.....	15
Figure 10-Remove the screws and nuts that hold the zig-zag shield to back and front of chassis	15
Figure 11-Mount new PCB to shield and mounting brackets.....	16
Figure 12-Schematic of Power Supply	20

Section 1: About This Manual

This manual gives the information needed to build and install the upgraded power supply for Dynaco's PAT-5 Preamp. This manual covers the assembly of Rev E hardware.

The Rev E version can support up to 100 mA load current, nearly twice of what earlier versions can support. This is enough current to power a complete upgrade of the both the line stage and the phono stages, as those stages run exclusively from +/-15V. The Rev E power supply will also power a stock set of boards (line stage and phono) with clean and quiet power.

Who Should Attempt this Project?

You can build this kit if you can:

1. Solder (using normal rosin core solder and a soldering iron).
2. Use simple hand tools like screwdrivers, wire cutters, and pliers.
3. Read and follow directions.

It helps if you:

1. know a bit about electronics, or
2. have a friend who knows a bit about electronics
3. can get to YouTube to watch a few helpful videos about the assembly process (none are posted as of this version of the manual).

Tools you'll need

You'll need the following tools:

1. Phillips screwdriver (#1 and #2), regular screw-drivers.
2. Pliers or nut drivers suitable for #4 and #6 hardware
3. needle nose pliers (helpful, but not strictly necessary)
4. pencil type soldering iron of 25 to 50 Watts (no huge honking soldering guns or blowtorches)
5. wire cutters and strippers
6. multi-meter to measure power supply voltages and confirm resistor values (strongly recommended)!

Helpful Tools

These tools aren't strictly necessary, but make building the kit easier.

1. magnifying glass, if you're over 42!
2. lead bending jig to form axial component leads to the correct span for insertion in the PCB.

Project Overview

The project consists of the following steps:

1. Building the circuit board.
2. Removing the old power supply
3. Installing and testing the new power supply
4. Completing re-assembly of the preamp.

Important Safety Notes

By purchasing, using, or assembling this kit, you have agreed to hold Akitika LLC harmless for any injuries you may receive in its assembly and/or use. To prevent injuries:

- Wear safety glasses when soldering or clipping wires to prevent eye injuries.
- Always unplug the power before working on the amplifier.
- Large capacitors hold lots of energy for a long time. Before you put your hands into the amplifier:
 - Pull the AC plug!
 - Wait 2 full minutes for the capacitors to discharge!
- Remove jewelry and rings from your hands and wrists, or anything that might dangle into the amplifier.
- If working on the equipment with the power on, keep one hand in your pocket, especially if you're near the power supply or power supply wires. This can prevent serious shocks.
- Build with a buddy nearby. If you've ignored all the previous advice, they can dial 911 or get you to the hospital.
- Read and understand the safety manuals of all the tools you use.

About Components

We reserve the right to make design/or component changes at any time without prior notification.

Recommended Solder

The kit must be assembled with 60/40 Rosin Core solder. The recommended diameter is 0.032 inches. Given the demise of Radio Shack, the easiest place to purchase some may be Amazon. You can also buy a 12 foot piece of solder, which should be enough to do this kit on the Updatemydynaco website.

Warranty

With the exception of fuses, Akitika LLC will replace for free any parts of a correctly assembled product that fails within one year of the date of purchase when the equipment has been used in home stereo applications. It is the responsibility of the kit builder to install the replacement part(s). This warranty applies to the original purchaser only. It does not apply to units that have been physically or electrically abused, modified without prior factory authorization, or assembled with other than 60/40 Rosin Core solder. Akitika LLC's liability shall in no event exceed the cost paid to Akitika LLC for the kit.

Section 2: Kit Building Hints

Yes, I know you want to ignore this section, and jump right into building the kit. However, please ***take a minute and read the advice of this section.*** I've condensed it into bullets so that even you guys who are in a hurry can benefit.

- Stop any time you're feeling confused, tired, or anxious. Taking breaks at those strategic times will keep the build enjoyable and greatly enhance your chances of first-time success.
- A soup bowl is your friend. Before you build a board, carefully empty the parts into a broad, flat, light colored soup bowl. That makes it easy to find the parts, and keeps them from getting lost.
- A digital ohm-meter is an easy way to make sure that you've picked the right resistor. It's a great cross-check on the resistor color code. Measure twice and solder once!
- A lead-bending jig can make for quicker, neater assembly. It's certainly not necessary.
- Is something in this manual confusing? Does something look wrong? Send your questions by email to dan@akitika.com or dan@updatemydynaco.com. You'll help yourself and everyone who builds the kit.

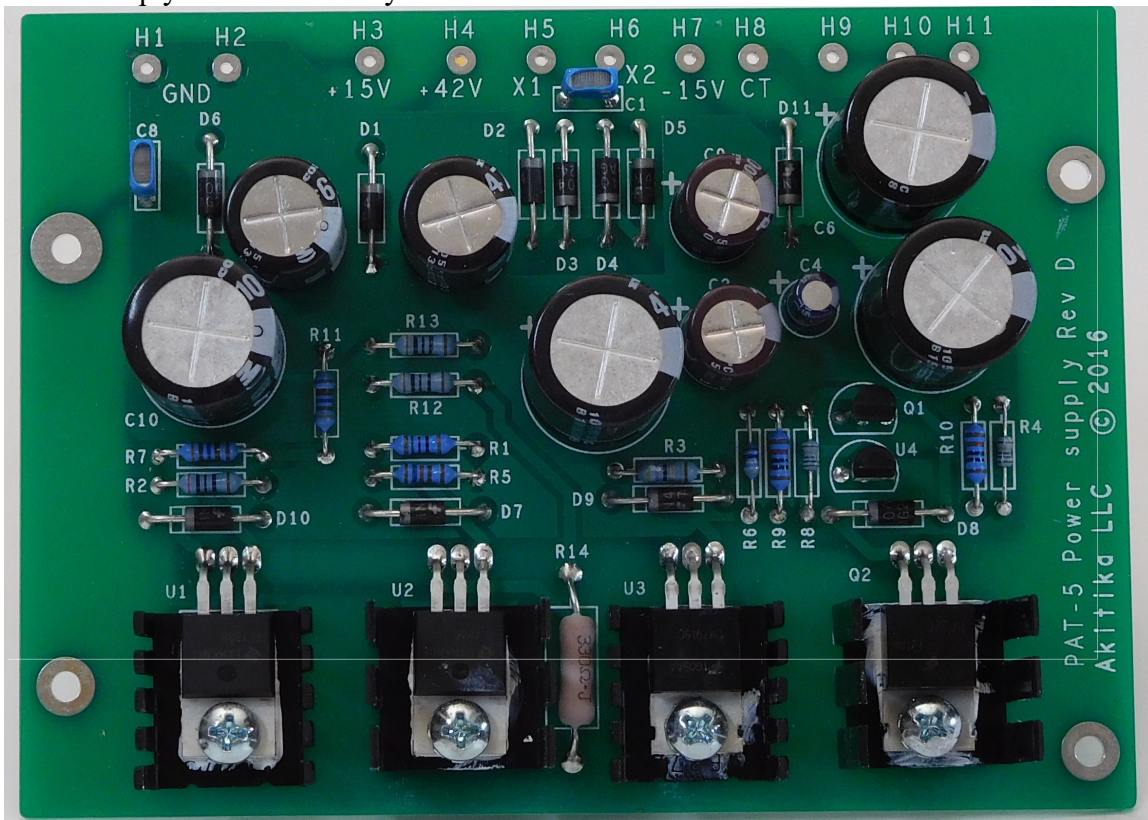

Figure 1-Assembled PAT-5 Power Supply. Note that U2, U3, and Q2 get tall heatsinks

Section 3: Building the Power Supply

This section details the process of building the power supply circuit board. Begin by carefully emptying the contents of the parts envelope into a broad soup bowl, as shown below. In general, you'll start with the components that lay closest to the board, working your way towards the taller components.

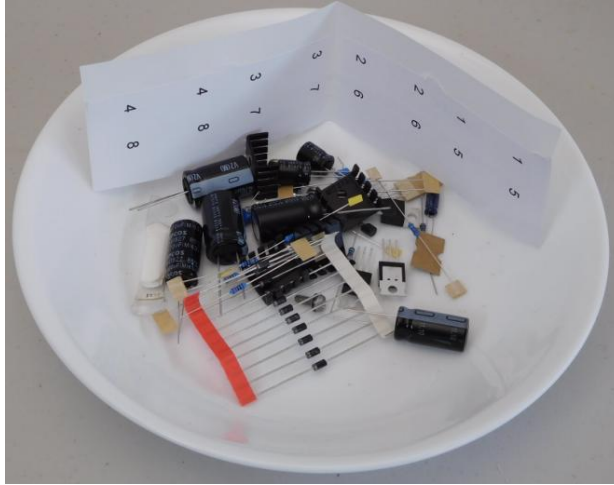

Figure 2-Empty the power supply components into a soup bowl

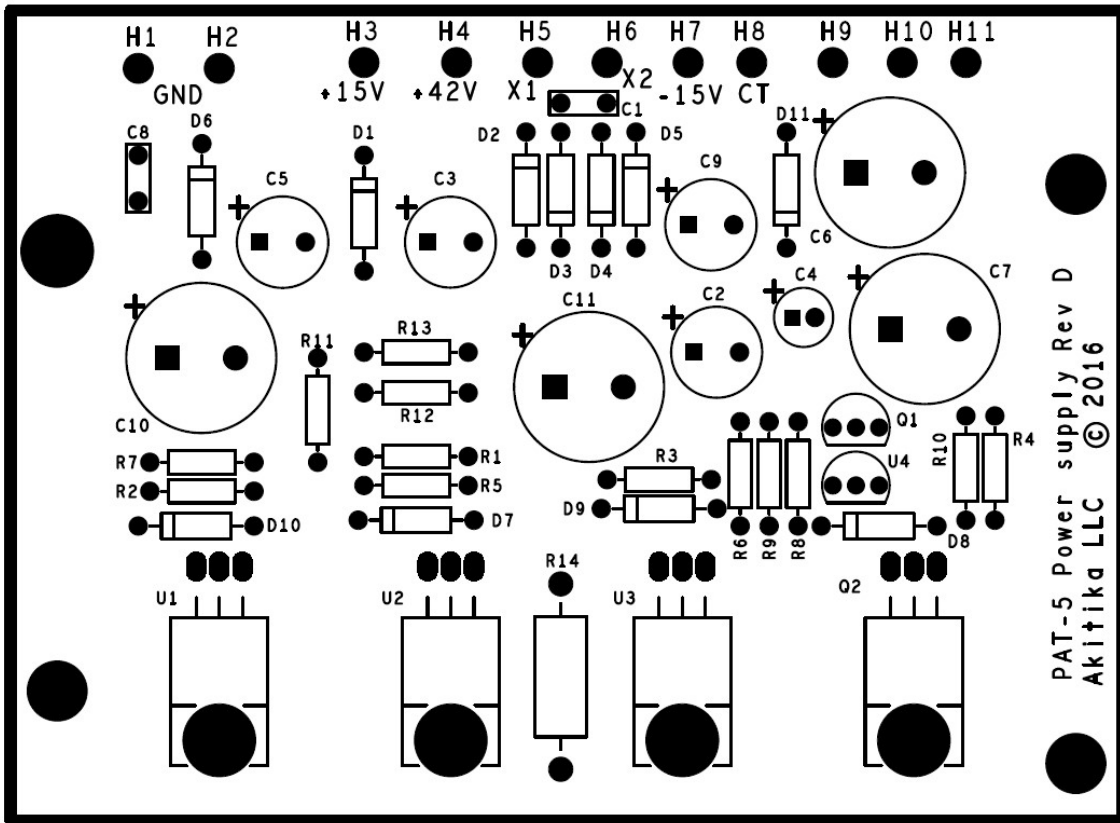

Figure 3-Silk screen shows power supply component locations

Component Order

You'll notice that the component designations in the directions don't go exactly in order. We have grouped them so that all components with the same value appear together. This makes assembly easier. You'll find in the parts kit that similar parts, e.g. 3 1K resistors, are typically (though not always) taped together.

Install the Resistors

In general, you install axial leaded components (like the resistors) by placing the body on the silk screen side of the board, and the leads through the indicated holes. Bend the leads over on the back of the board to keep the resistors from falling out until your solder them in place. Try to bend the leads in a direction that won't lead to solder bridges between traces that should remain disconnected.

We recommend the following procedure:

1. Insert all components of the same value or type
2. Bend the leads as described above.
3. Solder the leads on the back of the board.
4. Clip the leads.

Track your progress by placing a check-mark in the done column as you install each component. Note that R14, a 2 Watt power resistor, will be installed in a later section.

Bend resistor leads to 0.45" width			
Designation	Value	Color Code	Done ✓
R1	150	Brown, Green, Black, Black, Brown	
R2	200	Red, Black, Black, Black, Brown	
R12	200	Red, Black, Black, Black, Brown	
R13	200	Red, Black, Black, Black, Brown	
R3	2R49 ¹	Red, Yellow, White, Silver, Brown	
R4	100K	Brown, Black, Black, Orange, Brown	
R8	100K	Brown, Black, Black, Orange, Brown	
R5	1K62	Brown, Blue, Red, Brown, Brown	
R6	499	Yellow, White, White, Black, Brown	
R7	3K16	Orange, Brown, Blue, Brown, Brown	
R11	3K16	Orange, Brown, Blue, Brown, Brown	
R9	10K0	Brown, Black, Black, Red, Brown	
R10	10K0	Brown, Black, Black, Red, Brown	

Install the diodes

Diodes are polarized, having an anode and a cathode. When you insert the diode, match the banded end of the diode to the banded end of its representation on the silk screen.

Refer to Figure 1 to see what diodes look like, and how they should be oriented.

¹ 2R49 is another way of writing 2.49 Ohms. The "R" takes the place of the decimal point. Note that this resistor was 4.77 Ohms in Rev D and earlier. The change to 2.49 Ohms allows extra power to be delivered to support the installation of the phono upgrade kit.

Diodes – watch the polarity!			
Designation	Type	Rating, Marking, Description	Done? (✓)
D1	1N4004	400 PIV 1 Amp, 1N4004, rectifier diode	
D2	1N4004	400 PIV 1 Amp, 1N4004, rectifier diode	
D3	1N4004	400 PIV 1 Amp, 1N4004, rectifier diode	
D4	1N4004	400 PIV 1 Amp, 1N4004, rectifier diode	
D5	1N4004	400 PIV 1 Amp, 1N4004, rectifier diode	
D6	1N4004	400 PIV 1 Amp, 1N4004, rectifier diode	
D7	1N4004	400 PIV 1 Amp, 1N4004, rectifier diode	
D8	1N4004	400 PIV 1 Amp, 1N4004, rectifier diode	
D9	1N4004	400 PIV 1 Amp, 1N4004, rectifier diode	
D10	1N4004	400 PIV 1 Amp, 1N4004, rectifier diode	
D11	1N4004	400 PIV 1 Amp, 1N4004, rectifier diode	

Install R14

Designation	Value	Color Code	Done ✓
R14	330	330 Marked on the body	

Install the TO-220 Regulators, Power Transistors and Heatsinks

There are three regulators and one power transistor in TO-220 packages. Each TO-220 device fastens to the PCB (printed circuit board) with a heat-sink, heat-sink compound, a 6-32x3/8" screw and 6-32 keps nut (a nut with a built-in lock washer). Figure 4 shows the general assembly method. Note that there are two different size heat sinks, and one device, U2, will get two heatsinks!

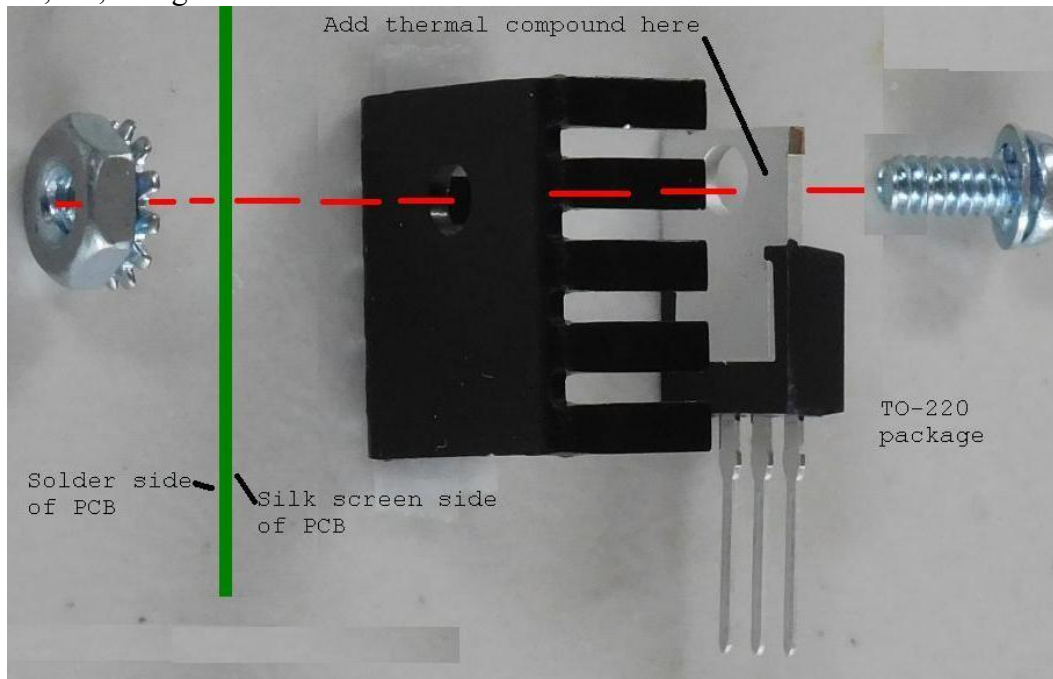

Figure 4-Regulator and Heat Sink Assembly Detail

Assembly Hint

You'll want to get the regulator or transistors leads bent so that when laying down, the mounting holes line up well. To do this, I put the leads halfway into their mounting holes, then slowly bend the regulator over into position while aiming the hole in the device for the hole in the PCB. With a little care, you won't have to jimmy it very much at all to get good registration.

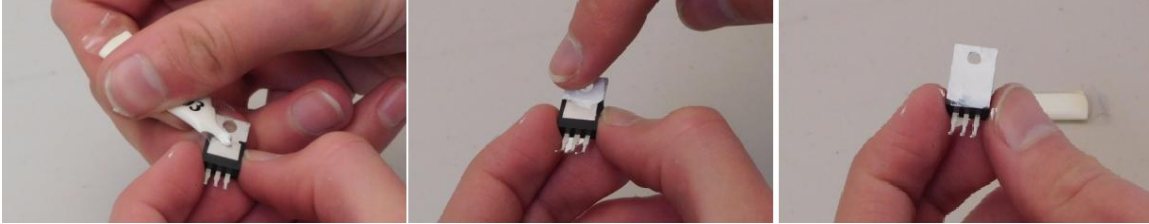

Figure 5-Applying thermal compound

Next, remove the device with the now pre-bent leads, and:

- Apply a thin film of thermal compound to the back TO-220 device just before assembling it to the heat-sink and PCB.
- Fasten the regulator in place with the hardware as shown in Figure 4 and Figure 6.
- Make sure to put the correct regulator type or transistor at the indicated location.
- Solder the leads after the heatsink, power device, and mounting hardware are secured in place. That keeps the power devices as cool as possible.

TO-220 Packaged Devices			
Designation	Type	Description, Marking	Done? (✓)
U1	TL783	High Voltage Positive Regulator, TL783. U1 gets one <u>short</u> heatsink mounted on the component side of the board.	
U2	TL783	High Voltage Positive Regulator, TL783. U2 gets one <u>long</u> heatsink on the component side of the board, and one <u>short</u> heatsink on the solder side of the board.	
U3	LM7915	Negative 15V Regulator, LM7915. U3 gets one <u>long</u> heatsink mounted on the component side of the board.	
Q2	TIP32C	PNP Power Transistor, TIP32C. Q2 gets one <u>long</u> heatsink mounted on the component side of the board.	

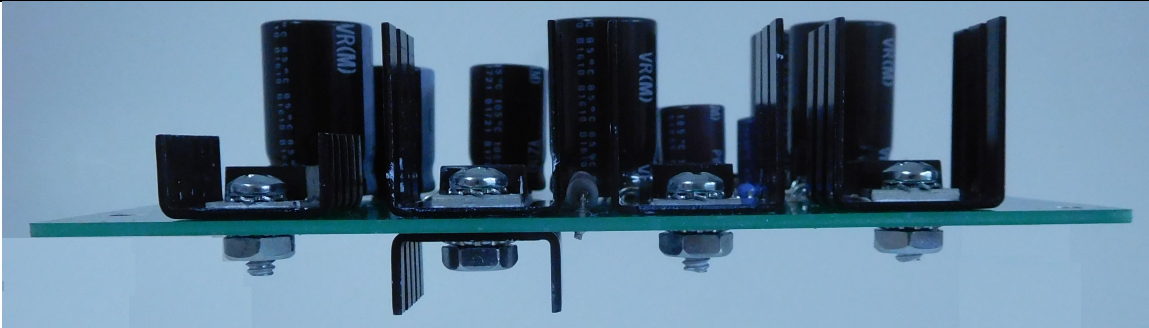

Figure 6-Heatsink Installation

Before you solder, please double check that the correct part is in the correct location.

It's good practice to keep the bottom heatsink straight so that it doesn't touch the near-by trace. It's actually not a problem if it does touch it, since the two nets are connected (Figure 7).

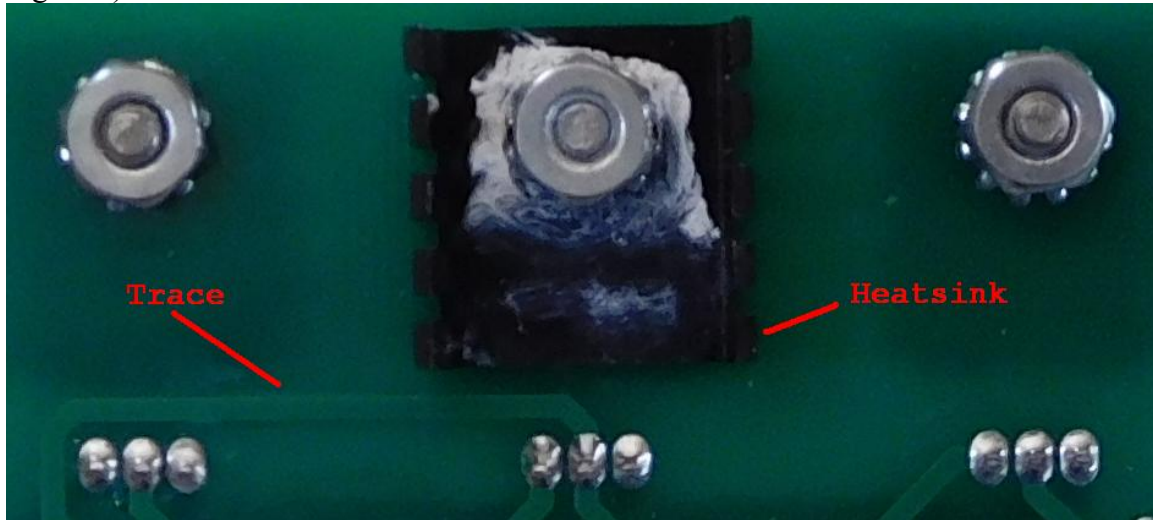

Figure 7-Line up the bottom heatsink to not touch the nearby trace

Install the Small Non-polar Capacitors

Orientation of these caps does not matter.

Designation	Description	Done? (✓)
C1	0.01 μ F, 400 Volt film capacitor, box capacitor	
C8	0.01 μ F, 400 Volt film capacitor, box capacitor	

Install Shunt Regulator and Small Transistor

Be very careful. The shunt regulator and small transistor come in the same type of package, known as a TO-92. They sit right next to each other on the PCB. However, their functions are very different. Make sure to read the writing on the packages to get the right device in the right place.

Shunt Regulator and Small Transistor

Designation	Value	Description, Marking	Done? (✓)
U4	TL431	Programmable Shunt Regulator, TO-92 package, look for "431" on the package.	
Q1	2N5401	High Voltage PNP transistor, TO-92 package, look for "5401" on the package	

Install the Electrolytic (polarized) Capacitors

Polarized Capacitors (*watch polarity and voltage rating*)

Designation	Value	Rating, Marking	Done? (✓)
C2	100 μ F	Electrolytic capacitor, 100 μ F 63 V, radial leads	
C9	100 μ F	Electrolytic capacitor, 100 μ F 63 V, radial leads	
C4	10 μ F	Electrolytic capacitor, 10 μ F 63 V, radial leads	
C3	470 μ F	Electrolytic capacitor, 470 μ F 63 V, radial leads	
C5	470 μ F	Electrolytic capacitor, 470 μ F 63 V, radial leads	
C6	470 μ F	Electrolytic capacitor, 470 μ F 100 V, radial leads	

C7	470 μ F	Electrolytic capacitor, 470 μ F 100 V, radial leads	
C10	470 μ F	Electrolytic capacitor, 470 μ F 100 V, radial leads	
C11	470 μ F	Electrolytic capacitor, 470 μ F 100 V, radial leads	

Check your work

Look over the board to verify that:

1. All components are soldered.
2. No solder bridges are apparent.
3. Polarity of the electrolytic capacitors is correct.
4. The right regulator is in the right location.
5. The heatsink hardware is tight.
6. Diode polarity is correct.

If everything looks good, you're ready to install the power supply into your PAT-5.

Checking the preamp and old power supply

For these steps, use your soup bowl to safely store the mechanical parts you'll remove as you disassemble and re-assemble your PAT-5.

This section assumes that the original power supply and preamp was nominally working. We'll measure the original voltages to confirm that assumption. Here are the steps.

Checking the preamp and old power supply	
Removing the cover	Done? (✓)
<i>Pull the Preamp's AC plug and wait 1 minute before going on.</i>	
Remove the four black slotted-head screws, 2 on each side of the preamp, that hold the top cover in place.	
Remove the one screw from the center of the back of the top cover.	
Remove the cover and set it aside.	
Measure the voltages	
Set your meter to DC volts.	
Make sure that your PAT-5 is completely disconnected from any other equipment.	
<i>Plug the PAT-5 into the AC power socket. Note: There are potentially lethal voltages inside the PAT-5 from the instant it is plugged in, regardless of the state of the ON-OFF switch!</i>	
Measure the voltage from eyelet 4 to eyelet 1. It should be 42.5 Volts, plus or minus 3 Volts.	
Measure the voltage from eyelet 3 to eyelet 1. It should be 15 Volts, plus or minus 1.5 Volts.	
Measure the voltage from eyelet 7 to eyelet 1. It should be -15 Volts, plus or minus 1.5 Volts.	

Voltages outside of the indicated range may indicate a problem with the original power supply. Voltages less than the indicated amount (for example, if the -15 measured only -3) might indicate either a problem with the original power supply, or a problem with the PAT-5 circuits. If you have that condition, the next few instructions will help you sort it out.

Label, then de-solder the power supply wires	
Task	Done? (✓)
<i>Pull the Preamp's AC plug and wait 1 minute before going on.</i>	
The power supply PCB has numbered eyelets. Use the supplied labels to mark wires 1-8 to make assembly easier.	
If your PAT-5 was wired for 240 volt operation, then there also will be wires in eyelets 9, 10, and 11. Make your own masking tape labels for the wires that go there if they are present.	
If your power supply voltages were good on the previous page, then de-solder wires 1 through 8 (and 9, 10, and 11 for 240 volt preamps) and skip ahead to the section called "Removing the Old Power Supply".	
If your power supply voltages were bad on the previous page, then continue to the section, "If your voltages were out of tolerance".	

If your voltages were out of tolerance

If the voltage on eyelet 4 (nominally 42.5 Volts) was too low:	
Task	Done? (✓)
<i>Pull the Preamp's AC plug and wait 1 minute before going on.</i>	
Desolder the wire from eyelet 4 (nominally 42 volts). Place a DC current meter between eyelet 4 and the wire previously connected to it.	
<i>Plug the PAT-5 into the AC power socket. Note: There are potentially lethal voltages inside the PAT-5 from the instant it is plugged in, regardless of the state of the ON-OFF switch!</i>	
If the current is less than 10 mA then record the value of the current, and move to the next test.	

If the voltage on eyelet 3 (nominally 15 Volts) was too low:	
Task	Done? (✓)
<i>Pull the Preamp's AC plug and wait 1 minute before going on.</i>	
Desolder the wire from eyelet 3. Place a DC current meter between eyelet 3 and the wire previously connected to it.	
<i>Plug the PAT-5 into the AC power socket. Note: There are potentially lethal voltages inside the PAT-5 from the instant it is plugged in, regardless of the state of the ON-OFF switch!</i>	
If the current is less than 50 mA then record the value of the current, and move to the next test.	

If the voltage on eyelet 7 (nominally -15 Volts) was too low:	
Task	Done? (✓)
<i>Pull the Preamp's AC plug and wait 1 minute before going on.</i>	
Desolder the wire from eyelet 7. Place a DC current meter between eyelet 7 and the wire previously connected to it.	
<i>Plug the PAT-5 into the AC power socket. Note: There are potentially lethal voltages inside the PAT-5 from the instant it is plugged in, regardless of the</i>	

<i>state of the ON-OFF switch!</i>	
If the current is less than 50 mA then record the value of the current, and move on..	

If all the currents were within bounds, it is very likely that replacing the power supply will cure your problems.

If the power supply voltages under load were too high, then it is also very likely that replacing the power supply will cure your problems.

If the power supply voltages were too low, and the currents were too high, then you have problems in the circuit boards of your PAT-5.

If you're confused, send email to dan@akitika.com to further discuss your symptoms.

Removing the Old Power Supply

The mechanical design of the PAT-5 Preamp makes removing the old power supply a lot of work. Your soup bowl will come in handy again as a safe place to collect all the bits and pieces you'll need to remove to change the power supply.

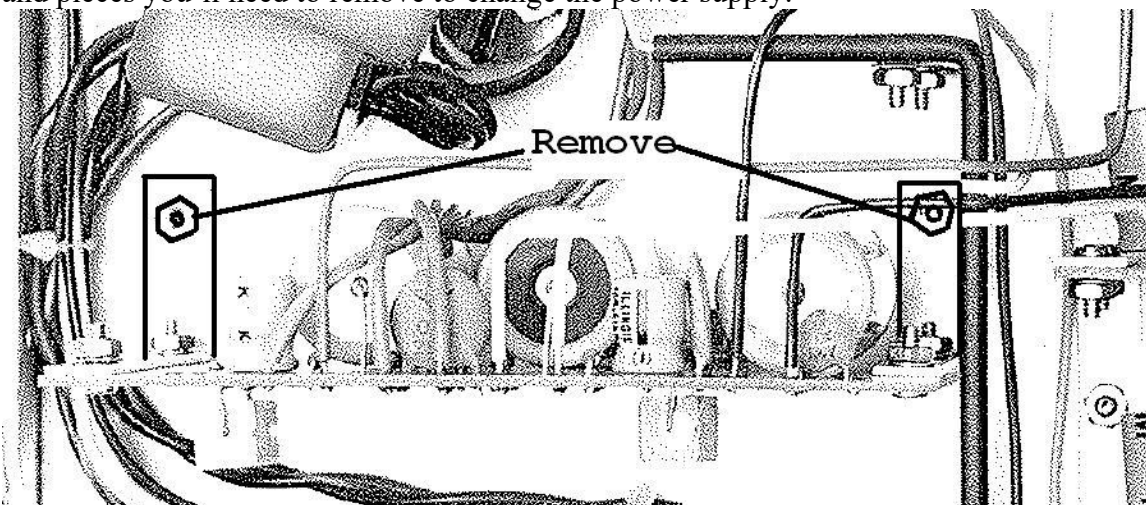

Figure 8-Remove hardware that holds power supply bracket to chassis floor

All of the following steps have the goal of removing the power supply and power supply shield, allowing replacement of the old power supply with the new.

Prepare to remove the old power supply	
	Done? (✓)
<i>Pull the Preamp's AC plug and wait 1 minute before going on.</i>	
Remove the two screws (one in each bracket) that hold the silver colored power supply mounting brackets to the bottom of the chassis. Easiest access is from the screws at the bottom of the chassis (Figure 8).	
Remove the four side screws that hold the back panel to the bottom of the chassis. (2 along each side, near the back, see Figure 9).	

Remove the two 4-40 screws and nuts from the back panel that hold the zig-zag shield and the power supply mounting bracket. Try to not let the nuts get away from you (Figure 10).	
Use a 1/16" Allen wrench to remove all the front panel knobs. I like to turn all the knobs fully counterclockwise before I start. It makes all the set screws available, and give me a consistent place to re-set all the knobs when it's time to re-assemble the preamp.	
Remove the 3 nuts on the control shafts that hold the front panel in place. These are typically located on the input selector, balance, and speaker controls. Remove the front panel	
Remove the two 4-40 screws and nuts that fasten the front of the zig-zag shield to the front panel (Figure 10).	
Lift the back panel slightly to clear the lip on the bottom of the chassis. There is enough slack in the wires to move the back panel back a bit. That opens up enough room to lift out the zig-zag shield and power supply.	
Lift the power supply and zig-zag shield assembly out of the preamp.	

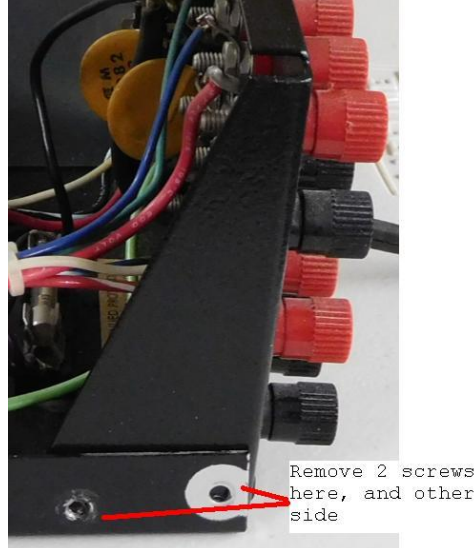

Figure 9-Remove these 2 screws and 2 screws on the opposite side

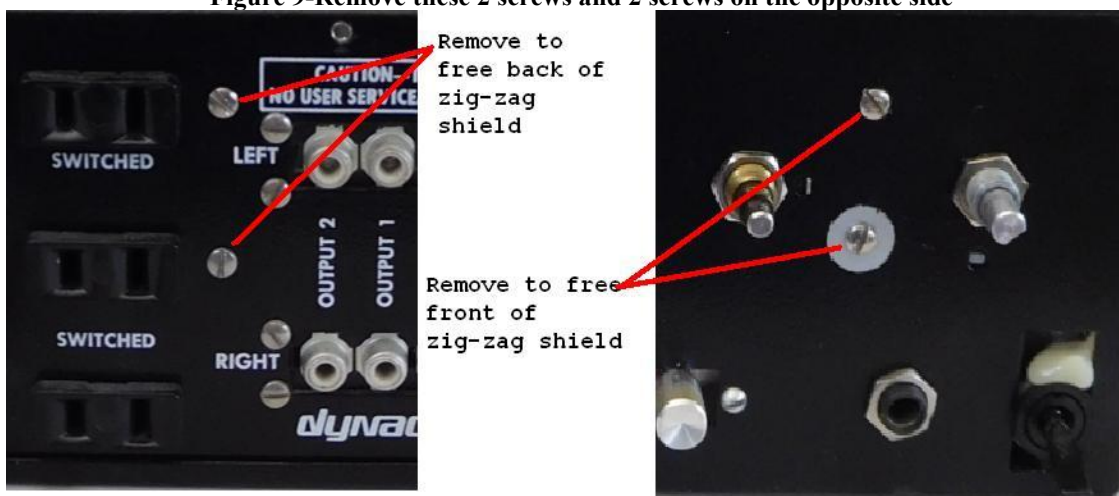

Figure 10-Remove the screws and nuts that hold the zig-zag shield to back and front of chassis

Remove the old power supply	
	Done? (✓)
Remove the four screws (two in each bracket) that hold the silver colored power supply mounting brackets to the power supply PCB.	

Installing the New Power Supply

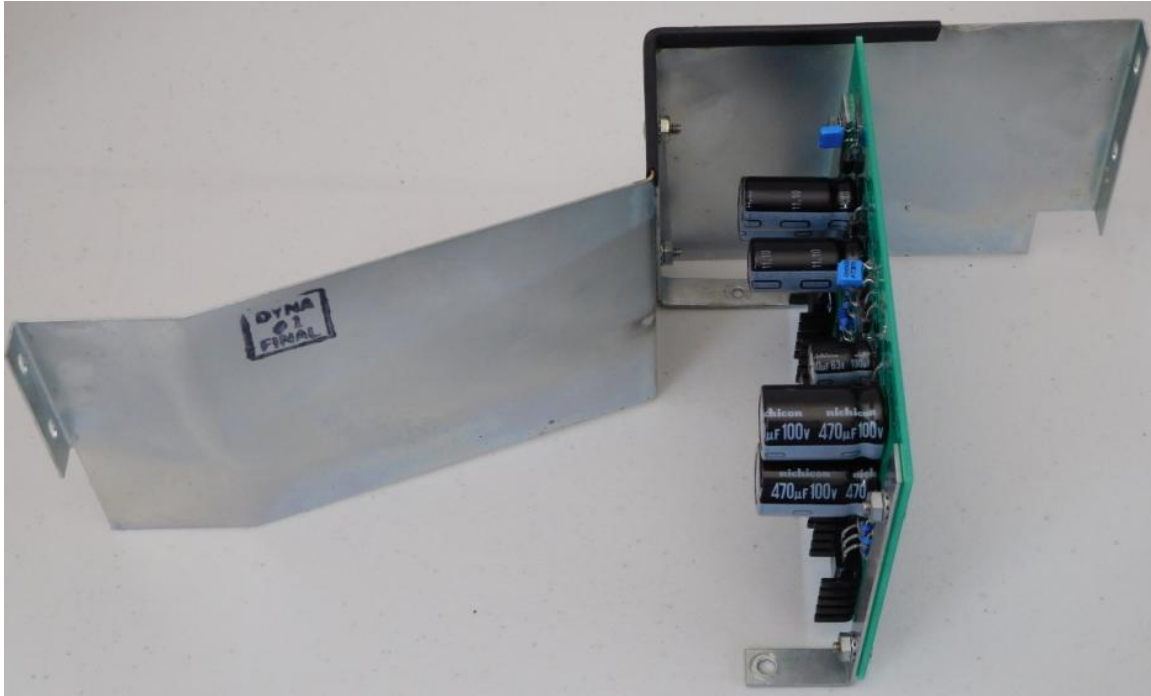

Figure 11-Mount new PCB to shield and mounting brackets

Installing the new power supply	
	Done? (✓)
<i>Pull the Preamp's AC plug and wait 1 minute before going on.</i>	
Mount the new power supply to the zig-zag shield using four 4-40 screws into the power supply mounting brackets.	
Return the zig-zag shield and power supply assembly into the chassis.	
Use two of the silver colored 4-40 screws and nuts to fasten the power supply mounting brackets to the bottom of the chassis.	
Use two silver colored 4-40 screws and nuts to fasten the zig-zag shield to the front panel. It's hard to get your fingers in place to hold the nuts. I like to hold the nut in place using double sided tape wrapped around the blade of a flat screw-driver. I then use a second screw-driver to turn the screw.	
Use four (2 on each side) ¼" hex head self tapping screws to fasten the back panel to the chassis bottom. Make sure that the back panel sits just inside the lip on the bottom of the chassis.	
Use two silver colored 4-40 screws and nuts to fasten the zig-zag shield to the back panel.	

Testing the power supply in place

Testing the new power supply	
	Done? (✓)
Reconnect wires 5, 6, and 8 from the transformer to the new power supply PCB. Insert them from the component side and solder them on the solder side.	
Clean-up and make sure that no tools are inside the preamp. You're about to power it on to test the output voltages. <u>Remember to be safe, as potentially lethal voltages will be present in the next step.</u>	
<i>Plug the PAT-5 into the AC power socket. Note: There are potentially lethal voltages inside the PAT-5 from the instant it is plugged in, regardless of the state of the ON-OFF switch!</i>	
Be alert for any signs of distress or smoke from the new power supply. If everything looks good, then move on to the following tests.	
Measure DC voltage from pin 3 to pin 1. It should be 15 Volts, plus or minus 1 volt.	
Measure DC voltage from pin 7 to pin 1. It should be -15 Volts, plus or minus 1 volt.	
Measure DC voltage from pin 4 to pin 1. It should be 42 Volts, plus or minus 2 volts.	
<i>Unplug the power cord and let the caps discharge for a minute before going on.</i>	
Reconnect wires 1, 2, 3, 4, and 7 to the new power supply PCB. Insert them from the component side and solder them on the solder side. Don't remove the wire tag until you double check that the wire is in the correct place.	
Dress these wires so they cross the zig-zag shield on top of the plastic edge guard. This will keep the wires from wearing through and shorting to ground.	
Inspect the inside of the preamp to make sure that there are no tools or wire bits left behind that could cause short circuits.	
<i>Be safe as you plug in the AC cord. Remember that lethal voltages will be present inside the preamp.</i>	
Verify that the power supply output voltages are still in tolerance after connecting the power supply to the rest of the preamp.	
Measure DC voltage from pin 3 to pin 1. It should be 15 Volts, plus or minus 1 volt.	
Measure DC voltage from pin 7 to pin 1. It should be -15 Volts, plus or minus 1 volt.	
Measure DC voltage from pin 4 to pin 1. It should be 42 Volts, plus or minus 2 volts.	
<i>Unplug the power cord and let the caps discharge for a minute before going on.</i>	

Final Re-Assembly

Once you have verified correct voltages, it's time to return your PAT-5 Preamp to service.

Dressing the wires	
<i>Unplug the power cord and let the caps discharge for a minute before going on.</i>	Done? (✓)
In normal operation, the hottest heatsink temperature, U2, will be around 77 C (170 F) ² . Dress the transformer and power wires away from the heatsinks. Use a plastic cable tie if you feel it's necessary to keep a wire spaced away from the heatsink(s).	
<i>If your PAT-5 is wired for 240 Volts:</i> <ul style="list-style-type: none">• <i>Connect the wires labeled 9, 10, and 11 to the eyelets H9, H10, and H11 on the power supply PCB. Without this connection, there will be no power to the power transformer.</i>• <i>Make sure that the wires in eyelets 9, 10, and 11 will not touch the top of the chassis or the power supply mounting brackets.</i>	

Putting on the Cover	
	Done? (✓)
Place the cover on the preamp. Note that there is only one correct orientation. You'll see the 4 holes on the sides line up when the orientation is correct.	
Install the 4 black screws (2 on each side) that hold the cover in place	
Install the black screw that holds the center-back of the cover to the back panel.	

About the Design

The new power supply design uses bigger capacitors and electronic regulation to dramatically decrease the amount of hum and power-line harmonics that appear in the power supply output voltages. Decreasing the hum in the power supply outputs can also decrease the hum present in the signal paths³.

The electronic regulation in the new power supply is much superior to that in the old power supply. The output voltage changes by much less than 10 mV as the output load moves between no load and full load. The stock design showed more than 1 volt of change from no-load to full load.

The load regulation method is still linear regulation, so there will be power dissipated in the heat sinks. They will get quite warm in normal operation. The design was tested with 150 Ohm loads on each of the 15-volt outputs (e.g. 100 mA), and a 4 kOhm load on the 42 volt output. Under those conditions, we measured the following temperatures on the

² The resistor bodies from the original supply ran even hotter!

³ Of course, there still may be some small amount of hum when you connect your PAT-5 to other components as a result of ground loops between the components.

tabs of the power devices (ambient temperature was 22 degrees C, input line voltage was 120 VRMS, 60 Hz):

- U1 – 43 degrees C
- U2 – 74 degrees C
- U3 – 82 degrees C
- Q2 – 92 degrees C

Even the hottest device, Q2, has a junction temperature that is $125-92=33$ C below the maximum recommended operating junction temperature. It is 58 C below the Absolute maximum operating junction temperature. The temperatures observed will decrease for loads less than 100 mA.

Typically, the worst-case load is for the combination of the improved line stage boards (16 mA per board, 32 mA for both boards) and the upgraded phono preamp (22.5 mA per board, 45 mA for both boards), for a total of 77 mA load on each of the plus 15 and minus 15 volt rails.

A spectrum analysis of the noise at full load shows very low noise. Note that -120 dBV is the equivalent of 1 micro-volt:

+15V

- -105 dBV @ 60 Hz
- -110 dBV @120 Hz (equivalent to 39.8 microvolts)
- -110 dBV @ 240 Hz
- Noise typically drops below -120 dBV above 2 kHz

+42V

- All power line harmonics <-103 dBV (noise floor in that region)
- Noise typically drops below -120 dBv above 1 kHz

-15V

- -105 dB @ 60 Hz
- -110 dB at @120 Hz
- Noise typically drops below -115 dBV at 300 Hz and above

Revisions

- 3.09 adds a bit more detail to 240V transformer wiring with regard to wires 9, 10, and 11.

Schematic

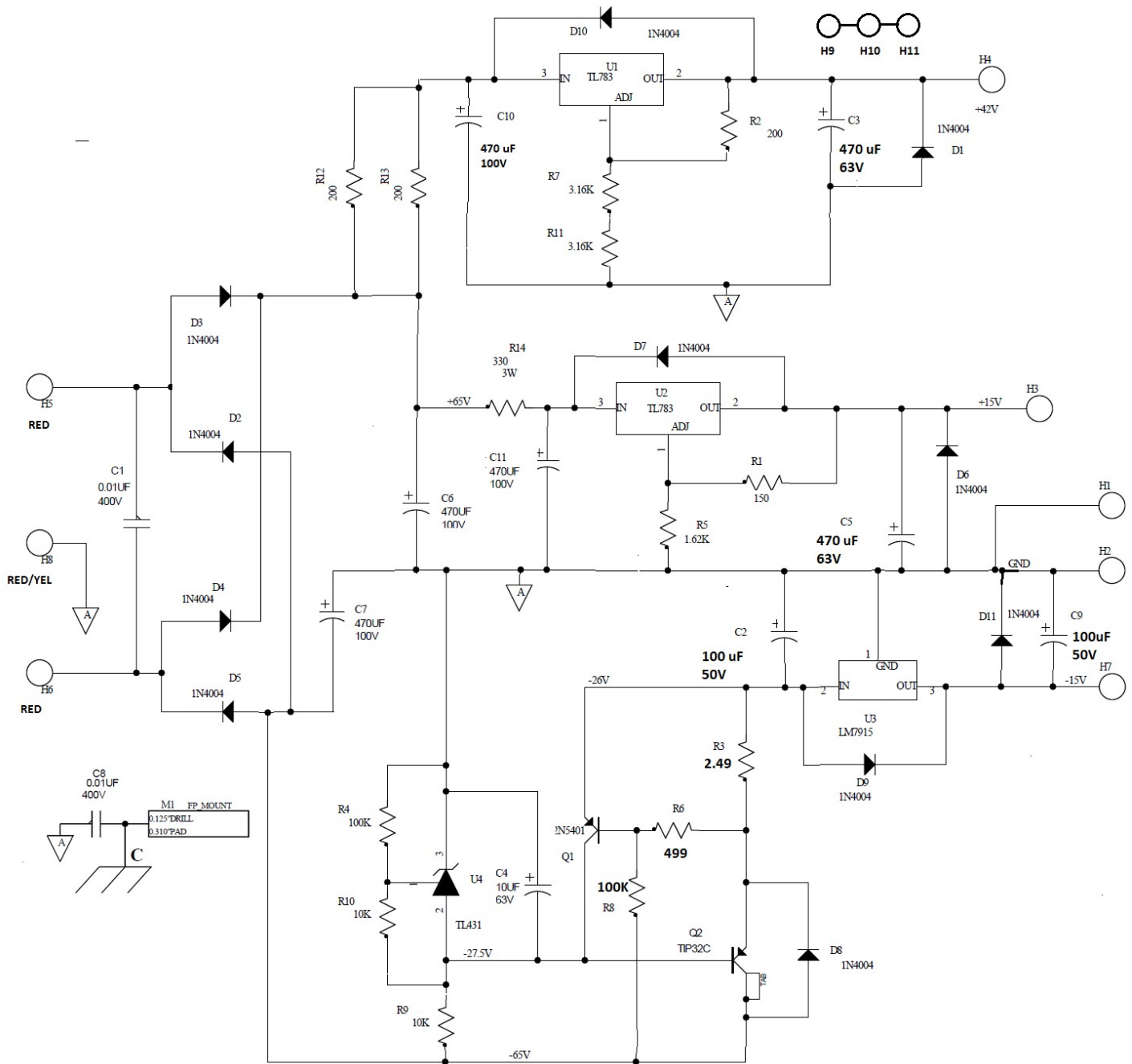

Figure 12-Schematic of Power Supply