

# ***Stereo 120 Speaker Mute [ST120PM]***

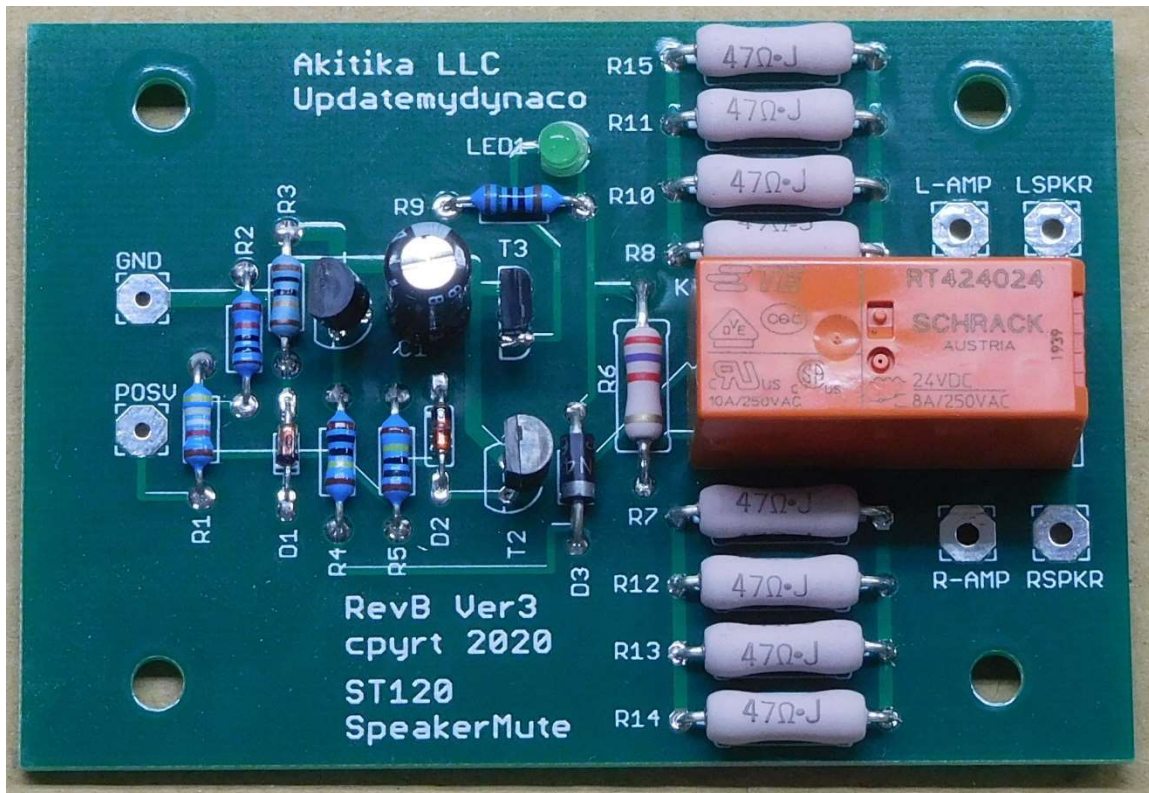

## ***Assembly/Installation MANUAL***

© 2020 Akitika, LLC  
All rights reserved  
Revision 1p03      December 4, 2020

## Table of Contents

Table of Contents .....	2
Table of Figures .....	2
Section 1: About This Manual .....	3
Who Should Attempt these Projects? .....	3
Tools and Supplies You'll Need .....	3
Recommended Solder .....	4
Project Overview .....	4
Important Safety Notes .....	4
Section 2: Building the PCB .....	5
Overview .....	5
Use a Soup Bowl .....	5
Install the resistors .....	6
Install the diodes .....	6
Install the LED .....	6
Install the Relay .....	7
Install the Transistors .....	7
Install the Electrolytic capacitors .....	7
Install the mounting brackets .....	7
Install wires on the new boards .....	8
Section 3: Installing the Speaker Mute board .....	9
Remove the Cover .....	9
Disconnect these wires from the red speaker binding posts .....	10
Solder these wires to the new (mute) board .....	10
Connect these mute pcb board wires to the amplifier .....	10
Mount the mute PCB .....	10
Using the mute PCB in a Stereo 410 .....	11
Final Sanity Checks .....	11
Timing Checks .....	11
Prepare to Reconnect your Stereo 120 to your Music System .....	11
Appendix 1: The Toothpick Trick .....	11

## Table of Figures

Figure 1-Empty the contents of the parts kit into a soup bowl .....	5
Figure 2-Silk screen (component) side of PCB .....	5
Figure 3-LED Orientation. The Anode lead is the longer of the two. ....	7
Figure 4-Installing the mounting brackets .....	8
Figure 5-mute board installed into Stereo 120 .....	9
Figure 6-Schematic of Stereo 120 speaker mute board .....	13

## Section 1: About This Manual

This manual gives the information you need to add a power on/off mute function to the Stereo 120 Power amplifier with Updatemydynaco upgrade modules. Here's the background.

The upgrade amplifier modules, like the original, have a capacitor coupled output. At start-up, the capacitor must charge up to its nominal 36-volt operating point. Special circuits in the upgrade amp and power supply boards control this charging to minimize the signals passed to the speakers on turn-on and turn-off. The resulting signals are rather small, but are still audible.

The speaker mute kit works like this:

- At power up, the speakers are disconnected by the muting relay. Instead, the output capacitors are connected to 12 Ohm resistors (actually 4 47 Ohm resistors in parallel).
- About 10 seconds after the power supply reaches its normal operating voltage, the output capacitor is charged, and the relay switches over to connect the amp to the speaker. The total elapsed time is about 20 seconds.
- About 2 seconds after turn-off, the mute circuit detects the decay in the power supply voltage, and turns off the relay before any noise can reach the speaker.

The Updatemydynaco upgrades typically leave the C11 chassis-mounted capacitor mounting holes open and available. The Speaker Mute kit mounts into the C11 mounting holes.

### ***Who Should Attempt these Projects?***

You can build this kit if you can:

1. solder (using normal rosin core solder and a soldering iron),
2. use simple hand tools like screwdrivers, wire cutters, and pliers, and
3. read and follow directions.

It helps if you:

1. know a bit about electronics, or
2. have a friend who knows a bit about electronics
3. can get to YouTube to watch a few helpful videos about the assembly process (not available as of this version of the manual)

### ***Tools and Supplies You'll Need***

You'll need the following tools:

1. flat blade screwdrivers for #4 and #6 screws, #2 Philips head screwdriver
2. needle nose pliers (helpful, but not strictly necessary)
3. pencil type soldering iron of 25 to 50 Watts (no huge honking soldering guns or blowtorches)
4. wire cutters and strippers
5. de-soldering tools (see Appendix 1)
6. Magnifying glass, if you're over 42!

7. A multi-meter for measuring Ohms and DC volts is a *really good idea*. With it, you can double-check your reading of the color code, making sure you get the right resistors in the right location.

### **Recommended Solder**

The kit must be assembled with 60/40 Rosin Core solder. The recommended diameter is 0.032 inches.

### **Project Overview**

Broadly, the project consists of the following steps:

1. Building the new circuit board.
2. Unplugging the Stereo 120 and removing the cover.
3. Installing the newly built circuit board.
4. Reassembling the Stereo 120.

### **Important Safety Notes**

By purchasing, using, or assembling this kit, you have agreed to hold AkitikA, LLC harmless for any injuries you may receive in its assembly and/or use. To prevent injuries:

- Wear safety glasses when soldering to prevent eye injuries.
- Always unplug the power before working on the equipment.
- Large capacitors hold lots of energy for a long time. Before you put your hands into the equipment:
  - Pull the AC plug!
  - Wait 1 full minute for the capacitors to discharge!
- Remove jewelry and rings from your hands and wrists, or anything that might dangle into the amplifier.
- If working in the amplifier, keep one hand in your pocket, especially if you're near the power supply or power supply wires. This can prevent serious shocks.
- Build with a buddy nearby. If you've ignored all the previous advice, they can dial 911 or get you to the hospital.

## Section 2: Building the PCB

### Overview

As you build this PCB, you will:

- Install the indicated component from the component (silk-screen) side.
- Solder the component on the solder side of the PCB.
- Make a check-mark as you complete the step.

You may find it convenient to install all resistors of one value first, as they will usually (but not always) be found taped together.

You'll begin with the components that sit closest to the board, and eventually move to the taller components. Begin with the resistors.

### Use a Soup Bowl

Empty the contents of parts envelopes into a broad, flat soup bowl. It will make it easier to find the parts. This makes building the PC boards more pleasant. It also minimizes the chance of losing a part on the floor.



Figure 1-Empty the contents of the parts kit into a soup bowl

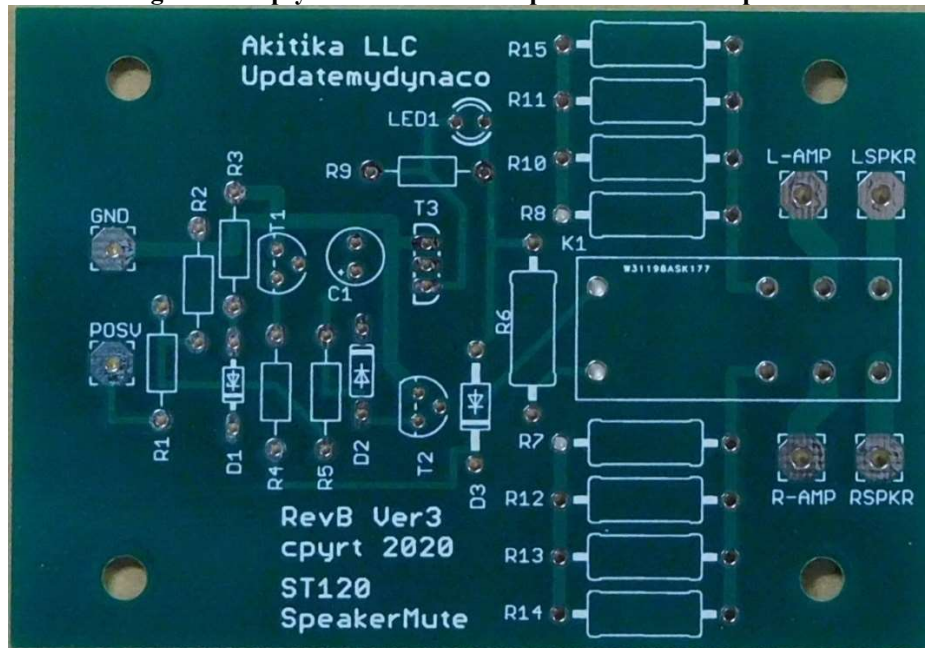

Figure 2-Silk screen (component) side of PCB

## ***Install the resistors***

If you'd like to use a lead-bender for the resistors, 0.4" works well for all the resistors. I strongly recommend using good light, magnification if necessary, and a digital ohmmeter to verify the correct resistor value before you install it. All of the resistors listed here are ¼ Watt 1% metal film resistors.

Desig	Value	Color Code	Done ✓
R1	49K9	Yellow, White, White, Red, Brown	
R2	10K0	Brown, Black, Black, Red, Brown	
R3	100K	Brown, Black, Black, Orange, Brown	
R4	1 Meg	Brown, Black, Black, Yellow, Brown	
R5	1 Meg	Brown, Black, Black, Yellow, Brown	
R9	150	Brown, Green, Black, Black, Brown	

The following resistors are 5% tolerance, 1 or 2 Watts as indicated.

Desig	Value	Color Code	Done ✓
R6	2700	1 Watt; Red, Violet, Red, Gold	
R7	47	2 Watt, marked 47	
R8	47	2 Watt, marked 47	
R10	47	2 Watt, marked 47	
R11	47	2 Watt, marked 47	
R12	47	2 Watt, marked 47	
R13	47	2 Watt, marked 47	
R14	47	2 Watt, marked 47	
R15	47	2 Watt, marked 47	

## ***Install the diodes***

The polarity of the diodes matters! Make sure that the banded end of the diode matches the banded end of the silk-screen symbol.

Desig	Value	Identification	Done ✓
D1	10V Zener	B10, glass body	
D2	200 volt switching diode	BAV20, glass body	
D3	400 Volt 1 Amp diode	1N4004, black body	

## ***Install the LED***

The LED is polarized, so its orientation is critical! Fresh out of the parts bowl, you'll notice that one lead is longer than the other.

- The longer lead is the anode (positive lead)
- The shorter lead is the cathode (negative lead)

On many LEDs, but not all, you'll also see that there is a flat side on the cathode (negative, short lead) side of the package. Still, the most reliable way to identify the polarity is by the longer lead.

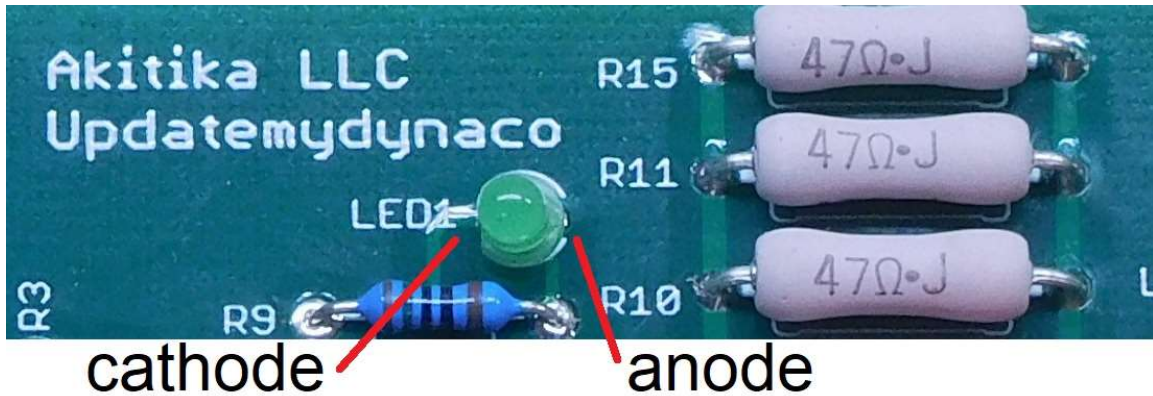

Figure 3-LED Orientation. The Anode lead is the longer of the two.

### ***Install the Relay***

Here's the recommended procedure for installing the relay.

1. Place the relay into the board.
2. For now, just solder two corner pins.
3. Check the relay to make sure that it sits flat on the board and that all the pins are projecting thru the PCB.
4. If the relay doesn't sit flat, then melt the solder on the corner pins, one at a time, as you press the relay down to the PCB.
5. Once you're sure that the relay sits flat on the board, solder the rest of the pins.

### ***Install the Transistors***

Make sure to match the shape of the transistor body to the outline on the silk screen.

Desig	Value	Marking <sup>1</sup>	Done ✓
T1	2N3904, 60 volt NPN	3904	
T2	2N3904, 60 volt NPN	3904	
T3	ZVN2110A, 100 volt N channel MOSFET	2110	

### ***Install the Electrolytic capacitors***

Electrolytic capacitors are polarized. You must observe the correct polarity. Make sure that the negative sign on the capacitor is at the opposite end from the positive sign on the silk-screen.

Desig	Value	Done ✓
C1	47 $\mu$ F@50 Volts, might also be 35V	

### ***Install the mounting brackets***

Use two of the supplied 6-32x1/4" sems screws to fasten the brackets to the PCB. Insert the screws into the solder side and place the brackets on the component side. See Figure 4.

<sup>1</sup> There may be more numbers and letters on the package, but the presence of these numbers is enough to correctly identify these parts.

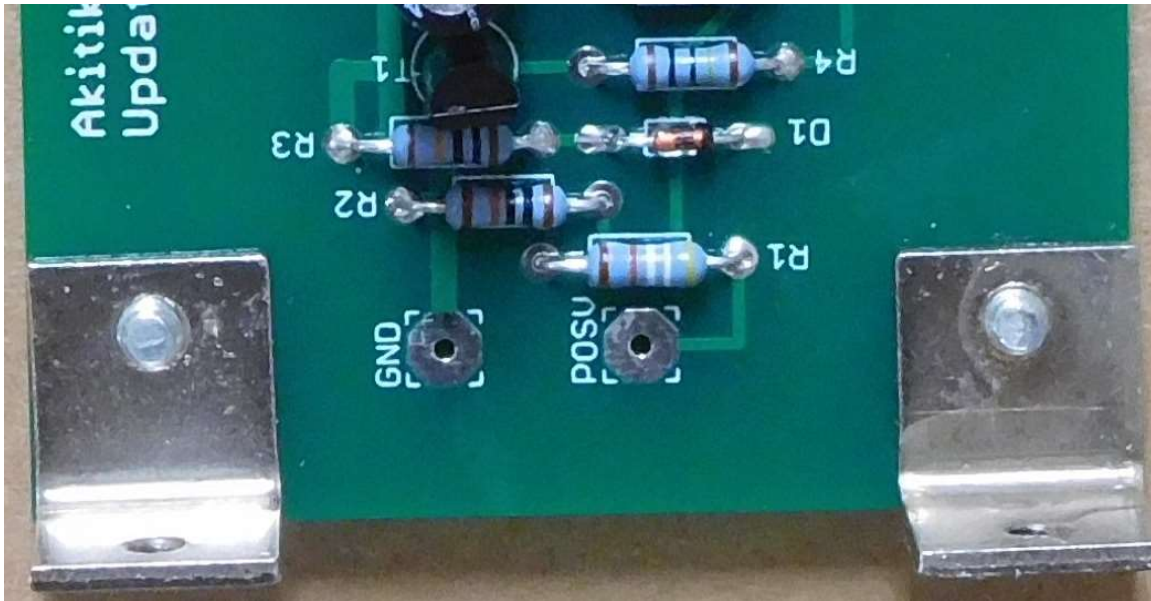

Figure 4-Installing the mounting brackets

### ***Install wires on the new boards***

Locate the 10" length of red/black twisted pair 22 AWG solid wire. Strip ¼" of the insulation from the red and black wires at one end of the twisted pair.

- Insert the RED wire into the POSV eyelet from the component side, and solder it on the solder side.
- Insert the BLACK wire into the GND eyelet from the component side and solder it on the solder side.

Locate the supplied 18 AWG stranded white wire and cut it into two equal length pieces. Strip ¼" of insulation from one end of each wire.

- Twist the strands of the bare end of one of the white wires. Insert the white wire into the component side of the L-SPKR eyelet. Solder it on the solder side.
- Twist the strands of the bare end of the other white wire. Insert this white wire into the component side of the R-SPKR eyelet. Solder it on the solder side.

This completes assembly of the speaker mute board and all the pre-wiring that can be done. Please inspect your work to verify:

- Resistor values
- Diode polarities
- Electrolytic capacitor polarity
- That all component leads have been soldered

In the next section, you will open your Stereo 120 and install the mute board.



## Section 3: Installing the Speaker Mute board

This section covers installation into a Stereo 120. It assumes that you have installed upgrades that leave the old C11 mounting holes available.

### **Remove the Cover**

1. Disconnect the Stereo 120 from your music system.
2. Unplug the power cord and allow the amp to sit for one minute before moving on.

Caution: Be sure that the power is unplugged! 120 VAC can be lethal! 240 VAC can be lethal!

3. Lay a towel out on your work surface to protect the amp.
4. Turn the amp upside down. Remove the 4 screws (2 along each edge of the bottom of the chassis) that hold the cover in place.
5. Grabbing both the cover and the main chassis, turn the amp right-side up.
6. Lift the cover straight up and set it aside in a safe place.

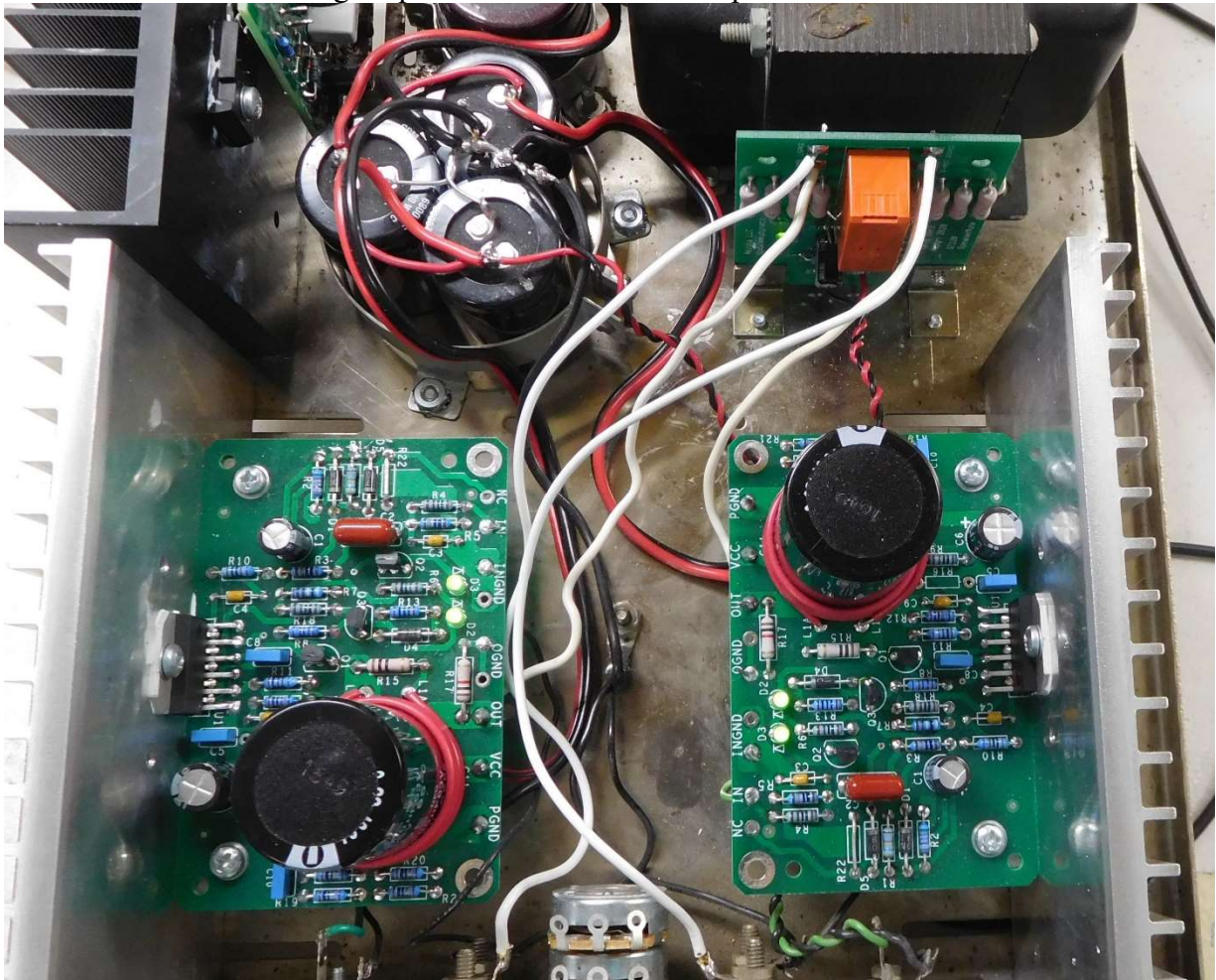

Figure 5-mute board installed into Stereo 120

### ***Disconnect these wires from the red speaker binding posts***

- At the RED LEFT speaker binding post end, disconnect the LEFT channel wire. Leave it connected to the LEFT channel OUT eyelet.
- At the RED RIGHT speaker binding post end, disconnect the RIGHT channel wire. Leave it connected to the RIGHT channel OUT eyelet.

### ***Solder these wires to the new (mute) board***

- Connect the free end of the amplifier board LEFT channel OUT wire to the L-AMP eyelet of the mute board. Insert it from the component side and solder it on the solder side.
- Connect the free end of the amplifier board RIGHT channel OUT wire to the R-AMP eyelet of the mute board. Insert it from the component side and solder it on the solder side.

### ***Connect these mute pcb board wires to the amplifier***

Place the module over the old C11 mounting holes. Don't screw it in yet. Placing it there will let you determine appropriate wire routing and lengths.

- Lay out the 18 AWG stranded that was pre-wired to the L-SPKR eyelet of the mute board. Make it a comfortable length that is fairly direct, but won't be so short as to make trouble shooting impossible. Somewhere around 9" will probably be comfortable.
  - Remove 3/8" of insulation, then twist and tin the end.
  - Connect this end of the wire to the lug that connects to the LEFT channel red speaker binding post.
- Lay out the 18 AWG stranded that was pre-wired to the R-SPKR eyelet of the mute board. Make it a comfortable length that is fairly direct, but won't be so short as to make trouble shooting impossible. Somewhere around 9" will probably be comfortable.
  - Remove 3/8" of insulation, then twist and tin the end.
  - Connect this end of the wire to the lug that connects to the RIGHT channel red speaker binding post.
- Connect the black wire of the black/red twisted 22 AWG pair to the negative side of the C12 capacitor (cluster).
- Connect the red wire of the black/red twisted 22 AWG pair to the positive side of the C12 capacitor (cluster).

### ***Mount the mute PCB***

Dress the leads down and line up the mounting holes in the mounting brackets with the old C11 mounting holes. Use the remaining two 6-32x1/4" sems screws (with built-in lock washers) to mount the board in place. Insert the screws into the bottom of the chassis and into the mounting holes on the brackets.

## ***Using the mute PCB in a Stereo 410***

The Stereo 410 doesn't have a speaker relay. When it turns on and off there may be thumps and pops. You can use the mute PCB in a Stereo 410. Here is a quick summary of the appropriate changes:

1. Don't install any of the 47 Ohm 2-Watt resistors into the mute board. If they are already there, then clip them out.
2. Connect positive 75 volts in the Stereo 410 to POSV on the mute PCB.
3. Connect ground from the Stereo 410 to GND on the mute PCB.
4. Disconnect the output of the right channel of the Stereo 410 amplifier from the right channel speaker binding post connection. Connect that wire instead to R-AMP on the mute PCB.
5. Use a piece of 18 AWG wire to connect the R-SPKR terminal of the mute board to the Stereo 410 right channel speaker PCB.
6. Disconnect the output of the left channel of the Stereo 410 amplifier from the left channel speaker binding post connection. Connect that wire instead to L-AMP on the mute PCB.
7. Use a piece of 18 AWG wire to connect the L-SPKR terminal of the mute board to the Stereo 410 left channel speaker PCB.

Note that the Stereo 120 mute PCB does not have any DC protection or sensing. Note also that if the relay opens during a large DC fault, damage may result to the relay contacts.

## ***Final Sanity Checks***

### **Timing Checks**

Begin with the power switch off. Turn the power switch on, and time how long it takes for the LED to turn on. It should be around 20 seconds.

Beginning with the LED on, turn off the power switch. The LED should turn off in about 2 seconds.

## ***Prepare to Reconnect your Stereo 120 to your Music System***

- Turn off the power.
- Remove the AC plug from the wall socket.
- Replace the cover and re-install the 4 screws that hold the cover in place.
- Reinstall the Stereo 120 to your music system.

## ***Appendix 1: The Toothpick Trick***

This appendix describes an easy way to clear the solder from a hole in the PCB. It can also be used to clear the solder from terminals on pots or jacks. Doing so makes it easier to install a new component, or reinstall wires that were temporarily removed to allow access to some other component.

All you'll need is a soldering iron and some toothpicks with sharp points. The diameter of the pointed part of the toothpick must be smaller than the diameter of the hole that you're trying to clear.

Heat the solder land on the component side of the board until the solder flows. Insert the toothpick from the component side of the board while pushing and twisting the toothpick. If the solder has melted, the toothpick should push through the board, displacing the solder. Remove the soldering iron, but let the toothpick remain in the hole until the solder has solidified. Now remove the toothpick. There should be a hole through the solder sufficiently large to allow you to insert the component lead or wire.

Sometimes, a bit of the toothpick will break off in the hole. If this happens, use a stiff piece of wire to push the toothpick fragment out of the hole.

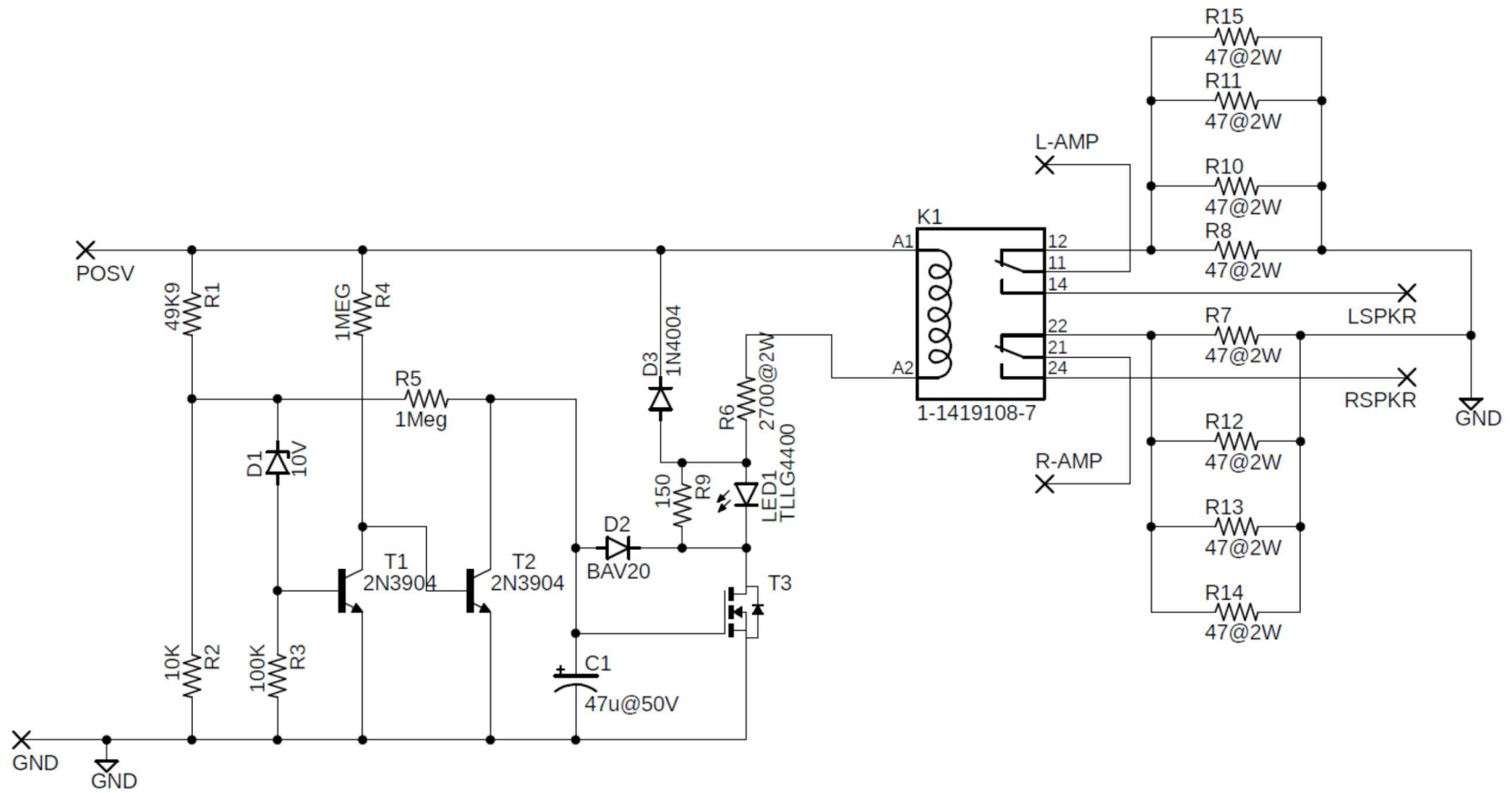

Figure 6-Schematic of Stereo 120 speaker mute board