

PAT-4 SELECTOR SWITCH REPLACEMENT (PAT4SEL) ASSEMBLY MANUAL

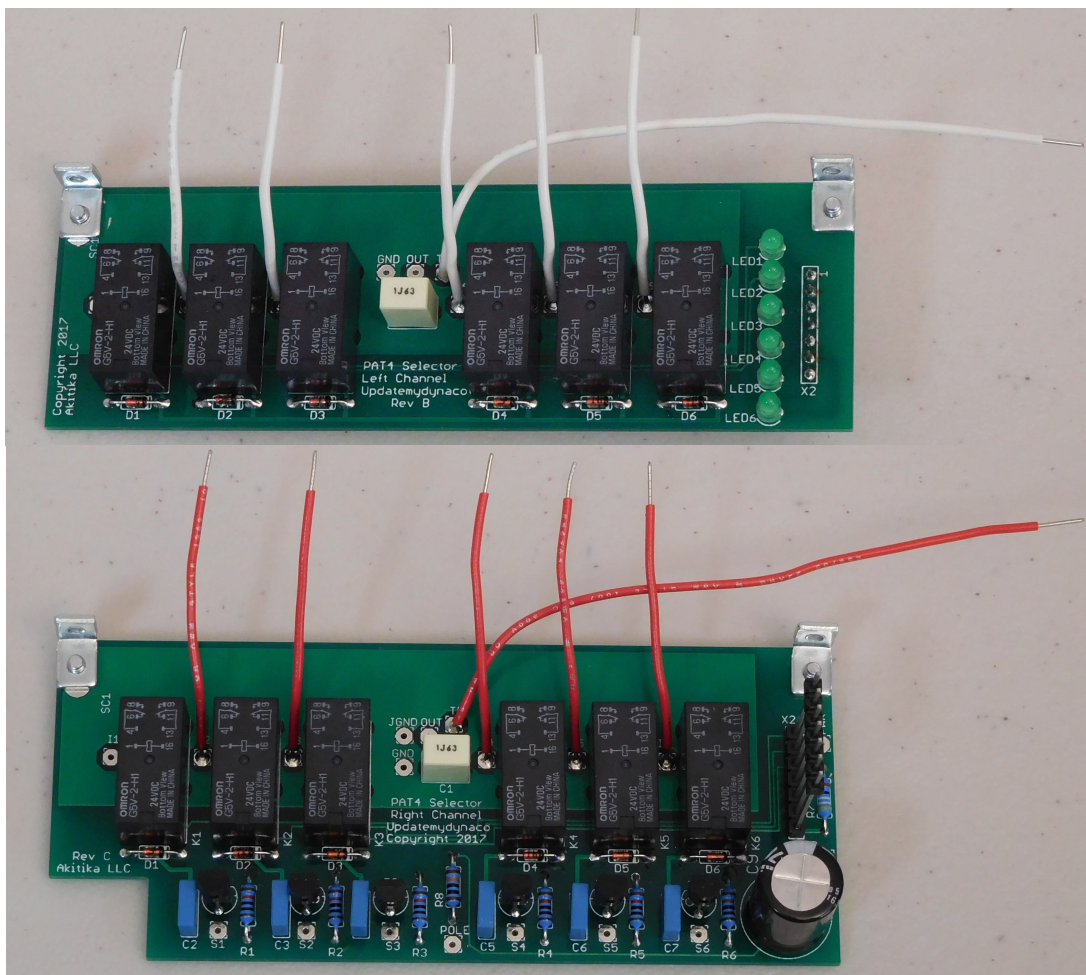

© 2017-2021 Akitika, LLC
All rights reserved
Revision 1p19 March 11, 2023

Table of Contents

Table of Contents	2
Table of Figures	3
Section 1: About This Manual	4
Who Should Attempt these Projects?	4
Tools and Supplies You'll Need	4
Recommended Solder	5
Project Overview	5
Important Safety Notes	5
Section 2: Building the Selector Switch Upgrade.....	6
Building the PAT4SEL Circuit Boards.....	6
Building the Left Channel PCB	6
Component Order.....	6
Install the Diodes	6
Install the LEDs	8
Install the Capacitor	8
Install the Relays.....	9
Install the RCA Signal Wires.....	9
Install the connector.....	10
Install the mounting brackets.....	10
Building the Right Channel PCB.....	11
Install the Diodes	11
Install the resistors	12
Install the Relays.....	12
Install the Transistors.....	12
Install the Capacitors.....	13
Install the RCA Signal Wires.....	13
Install the electrolytic capacitor	14
Install the connector.....	14
Install the mounting brackets	15
Remove the cover	15
Overview of selector switch connections	15
Get your phono section ready for the new selector switch	16
Modify two selector switch connections.....	17
Identify two remaining wires to the tape monitor switch	17
Remove the Original selector switch	19
Installing the PCBs in your PAT-4 Preamp.....	19
Pre-wiring the Right Channel PCB.....	19
Installing the Right Channel PCB.....	20
Installing the Left Channel PCB.....	26
Re-assemble your pre-amp and pre-test your work	26
Schematics	28
Appendix 1: The Toothpick Trick	30
Appendix 2 - Preparing a Shielded Cable End	31
Appendix 3 - Resistor Color Code.....	33

Table of Figures

Figure 1-Component side of the left channel PCB before loading.....	6
Figure 2-match black band on diode to white band on silk-screen.....	7
Figure 3-Anode and Cathode for the LEDs	8
Figure 4-Signal wire preparation	9
Figure 5-showing connector installed into the left channel PCB	10
Figure 6-Bracket installation detail.....	10
Figure 7-Component side of the right channel PCB before loading.....	11
Figure 8-Right channel signal wire preparation.....	13
Figure 9-Short side of connector solders into the PCB.....	14
Figure 10-Showing the connector installed into the right channel PCB.....	14
Figure 11-Bracket installation detail.....	15
Figure 12-wired selector switch.....	20
Figure 13-Wiring the new selector switch, alternate view	20
Figure 14-Preliminary look at installed selector replacement	22
Figure 15-Wiring the new jack arrangement (some wires not show to avoid clutter).....	23
Figure 16-Original Back Panel Wiring, 1 mfd caps get removed and replaced by caps on the new selector PCBs	24
Figure 17-Front Panel Wiring.....	25
Figure 18-Right channel selector board schematics	28
Figure 19-Schematic of left channel circuit board.....	29
Figure 20- Shield wire end prep completed (right channel)	32
Figure 21-demonstrating the resistor color code	33

Section 1: About This Manual

This manual gives the information you need to build and install the PAT-4 Selector Switch Replacement (and Upgrade), part number PAT4SEL, into your Dynaco PAT-4 Preamp. As of this writing, the following other PAT-4 upgrades are available from Updatemydynaco, a division of Akitika LLC:

- Blue Light Kit (BLUE)
- Line Amp Distortion Reducer (DRD4)
- Tone Control Switch (TCS)
- Electronically Regulated Power Supply (PAT4PWR)
- Line Stage Replacement Components (P4LSRC)
- Phono section upgrade (PAT4LP)
- Phono section replacement (PAT4PPR)
- Phono and Line Stage Upgrade and Renewal (PAT4RENEW)

This table compares the original selector switch to the PAT4SEL upgrade.

Original Selector Switch	PAT4SEL upgrade
Open switch contacts corrode, making for flaky operation.	Switch contacts sealed in relay prevent corrosion and keep reliable contact.
Long distance between RCA jack and selector switch picks up noise	Switch network is right next to the RCA jacks, with short traces over ground-planes. Selected input travels over shielded cable.
Switches low-level signals, subject to noise pickup.	All signals switched are high level, avoiding noise pickup.
3 low level inputs and 3 high level inputs.	1 low level input (phono) and 5 high level inputs.

Please note that installing this kit requires either:

1. Re-wiring of the existing phono preamp, or
2. Use of the PAT4PPR phono preamp.

Who Should Attempt these Projects?

You can build this kit if you can:

1. solder (using normal rosin core solder and a soldering iron),
2. use simple hand tools like screwdrivers, wire cutters, and pliers, and
3. Read and follow directions.

It helps if you:

1. know a bit about electronics, or
2. have a friend who knows a bit about electronics
3. can get to YouTube to watch a few helpful videos about the assembly process (not available as of this version of the manual)

Tools and Supplies You'll Need

You'll need the following tools:

1. flat blade screwdrivers for #4 and #6 screws, #2 Philips head screwdriver
2. needle nose pliers (helpful, but not strictly necessary)

3. pencil type soldering iron of 25 to 50 Watts (no huge honking soldering guns or blowtorches)
4. wire cutters and strippers
5. de-soldering tools (see the Appendix 1 and Appendix 2)
6. Magnifying glass, if you're over 42!
7. A multi-meter for measuring Ohms and DC volts is strongly recommended.

Recommended Solder

The kit must be assembled with 63/37 Rosin Core solder. The recommended diameter is 0.031 inches. Among many such sources of solder, I have used Radio Shack part number 64-009. It contains 8 oz. of solder, which is *much* more than you'll need to assemble this kit.

Project Overview

Broadly, the project consists of the following steps:

1. Building the PAT4SEL circuit boards.
2. Installing the assembled circuit boards and connecting them to the RCA jacks.
3. Installing and wiring the selector control switch and power.
4. Reassembling the preamp.

Important Safety Notes

By purchasing, using, or assembling this kit, you have agreed to hold Akitika, LLC harmless for any injuries you may receive in its assembly and/or use. To prevent injuries:

- Wear safety glasses when soldering to prevent eye injuries.
- Always unplug the power before working on the equipment.
- Large capacitors hold lots of energy for a long time. Before you put your hands into the equipment:
 - Pull the AC plug!
 - Wait 1 full minute for the capacitors to discharge!
- Remove jewelry and rings from your hands and wrists, or anything that might dangle into the amplifier.
- If working in the amplifier, keep one hand in your pocket, especially if you're near the power supply or power supply wires. This can prevent serious shocks.
- Build with a buddy nearby. If you've ignored all the previous advice, they can dial 911 or get you to the hospital.

Section 2: Building the Selector Switch Upgrade

Building the PAT4SEL Circuit Boards

There are two boards, one for the right channel, and the other for the left channel. We start with an overview on this page.

Building the Left Channel PCB

The bare PCB for the left channel is shown in Figure 1.

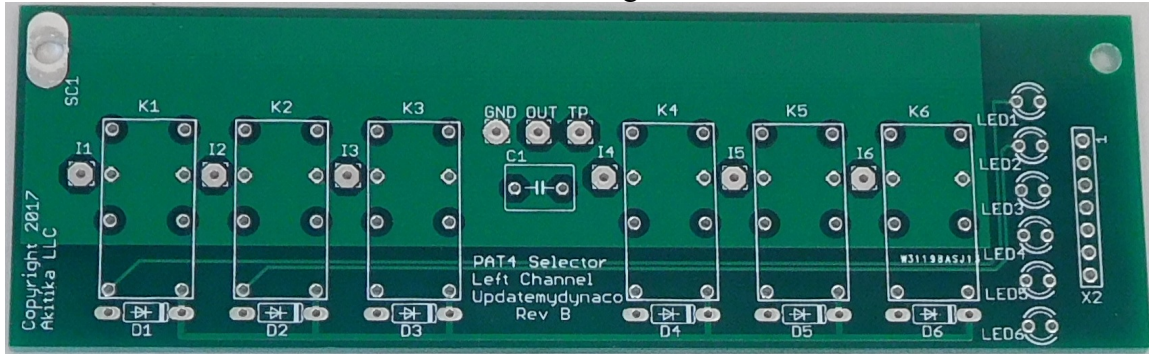
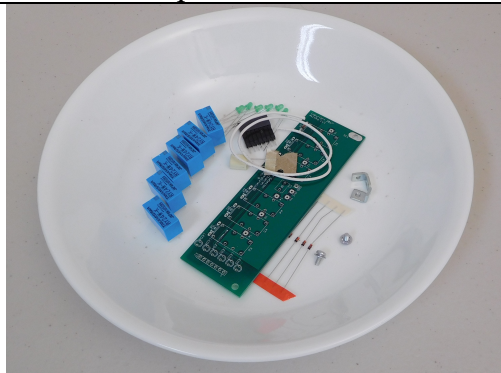

Figure 1-Component side of the left channel PCB before loading

Begin by carefully emptying the contents of the left channel parts envelope into a broad soup bowl, as shown below. In general, you'll start with the components that lay closest to the board, working your way towards the taller components. You will:

1. Install the diodes
2. Install the LEDs
3. Install the capacitor
4. Install the relays
5. Install the connector



Component Order

You'll notice that the component designations in the directions don't go exactly in order. We have grouped them so that all components with the same value appear together. This makes assembly easier. You'll find in the parts kit that similar parts, e.g. 6 1N4148 diodes, are typically (though not always) taped together.

Install the Diodes

In general, you install the components by placing the body on silk screen side of the board, and the leads through the indicated holes. Bend the leads over on the back of the board to keep the components from falling out until you solder them in place. Try to bend the leads in a direction that won't lead to solder bridges between traces that should remain disconnected.

We recommend the following procedure:

1. Insert all the components of the same value or type.
2. Bend the leads as described above.
3. Solder the leads on the back of the board.
4. Clip the leads.

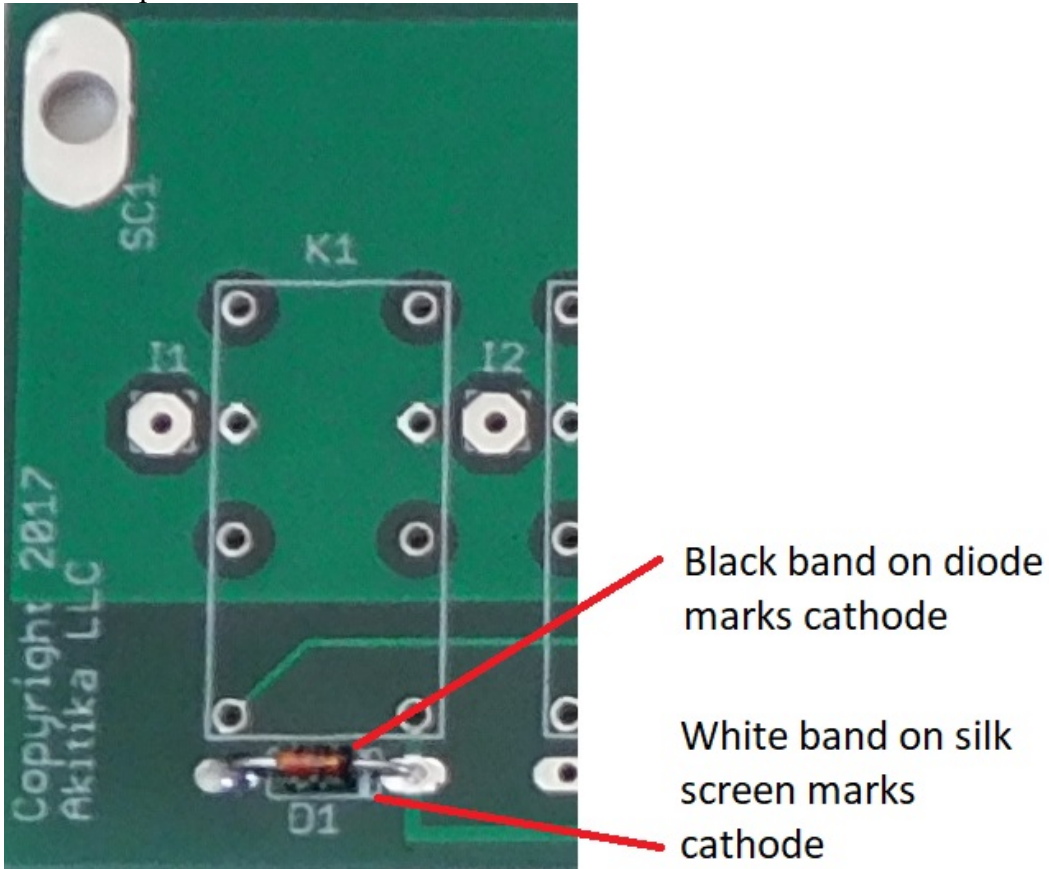

Figure 2-match black band on diode to white band on silk-screen

Track your progress by placing a check-mark in the done column as you install each diode. The diode leads are spaced at 0.3". If you have a lead bender, this will speed up and neaten your assembly. A lead bender is not required.

Note: Diodes are polarized. Make sure that the banded end of the diode is matched with the band on the silk-screen.			
Desig	Type	Marking	Done <input checked="" type="checkbox"/>
D1	1N4148, switching diode	4148	<input type="checkbox"/>
D2	1N4148, switching diode	4148	<input type="checkbox"/>
D3	1N4148, switching diode	4148	<input type="checkbox"/>
D4	1N4148, switching diode	4148	<input type="checkbox"/>
D5	1N4148, switching diode	4148	<input type="checkbox"/>
D6	1N4148, switching diode	4148	<input type="checkbox"/>

Install the LEDs

Now you'll install the LEDs. LEDs are polarized. Please be careful to insert them with the correct polarity. Here's how you can tell the polarity:

1. Given uncut leads, the slightly longer lead is the anode.
2. Viewed from above, the LED package outline is basically circular, with a flat on one side. That flat side marks the cathode.
3. All the LEDs have the same orientation for Anode and Cathode as shown

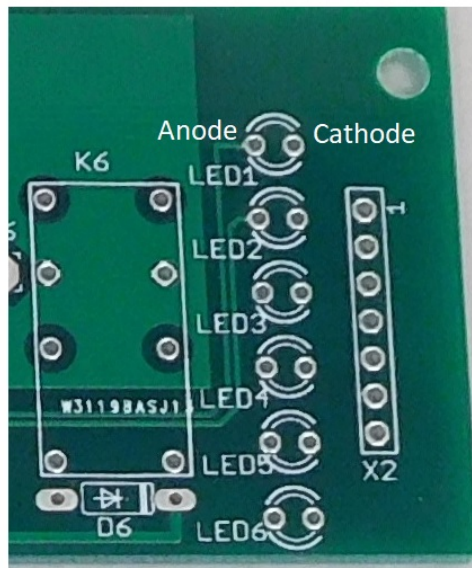

Figure 3-Anode and Cathode for the LEDs

Desig	Value	Marking	Done <input checked="" type="checkbox"/>
LED1	T1, green	None, but watch the polarity	<input type="checkbox"/>
LED2	T1, green	None, but watch the polarity	<input type="checkbox"/>
LED3	T1, green	None, but watch the polarity	<input type="checkbox"/>
LED4	T1, green	None, but watch the polarity	<input type="checkbox"/>
LED5	T1, green	None, but watch the polarity	<input type="checkbox"/>
LED6	T1, green	None, but watch the polarity	<input type="checkbox"/>

Install the Capacitor

The PAT4SEL also replaces the original electrolytic capacitor that coupled signals to the tape recorder input with a 1 uF film cap. Install that capacitor now.

Desig	Value	Marking	Done <input checked="" type="checkbox"/>
C1	1 μ F, 63V film	1J63	<input type="checkbox"/>

Install the Relays

Install the relays, making sure that they sit flat on the PCB. Here's a hint about how to do this:

1. Solder just two corner pins at first. Inspect the result to make sure that:
 - a. the relay is sitting flat on the board, and
 - b. All the relay pins are protruding through their holes in the PCB
2. Given that just two joints have been done at this point, it's easy to reheat one or both and adjust the relay as needed.
3. When everything looks good, solder the rest of the relay pins.
4. Inspect your work to make sure that every pin has been soldered.

Desig	Value	Done <input checked="" type="checkbox"/>
K1	24 volt coil, DPDT	<input type="checkbox"/>
K2	24 volt coil, DPDT	<input type="checkbox"/>
K3	24 volt coil, DPDT	<input type="checkbox"/>
K4	24 volt coil, DPDT	<input type="checkbox"/>
K5	24 volt coil, DPDT	<input type="checkbox"/>
K6	24 volt coil, DPDT	<input type="checkbox"/>

Install the RCA Signal Wires

Prepare 5 pieces of white 22 AWG wire as shown here:

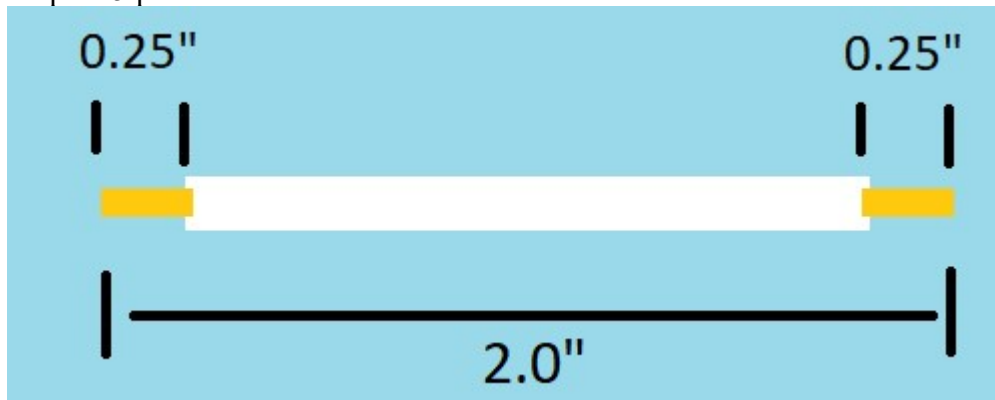

Figure 4-Signal wire preparation

Install one of each of these wires from the component side of the board, and solder them on the solder side of the board. Don't install into I1, as that will be done later.

Desig	Value	Done <input checked="" type="checkbox"/>
I2	White wire	<input type="checkbox"/>
I3	White wire	<input type="checkbox"/>
I4	White wire	<input type="checkbox"/>
I5	White wire	<input type="checkbox"/>
I6	White wire	<input type="checkbox"/>

Cut a 4.5" long piece of white 22 AWG solid wire. Strip ¼" of insulation from both ends. Insert one end of the wire into the TP eyelet from the component side of the board. Solder it on the solder side.

Install the connector

Install the connector from the solder side of the board, and solder it on the component side. Refer to the following picture before you solder. Make sure the connector sits flat on the board, with its body perpendicular to the plane of the board. Solder just one end pin first, then re-check. Re-heat and adjust as needed. Now, solder the other end pin, and re-check that the connector is sitting flat on the board, and is perpendicular to the board. When all that looks ok, solder the remaining 5 pins.

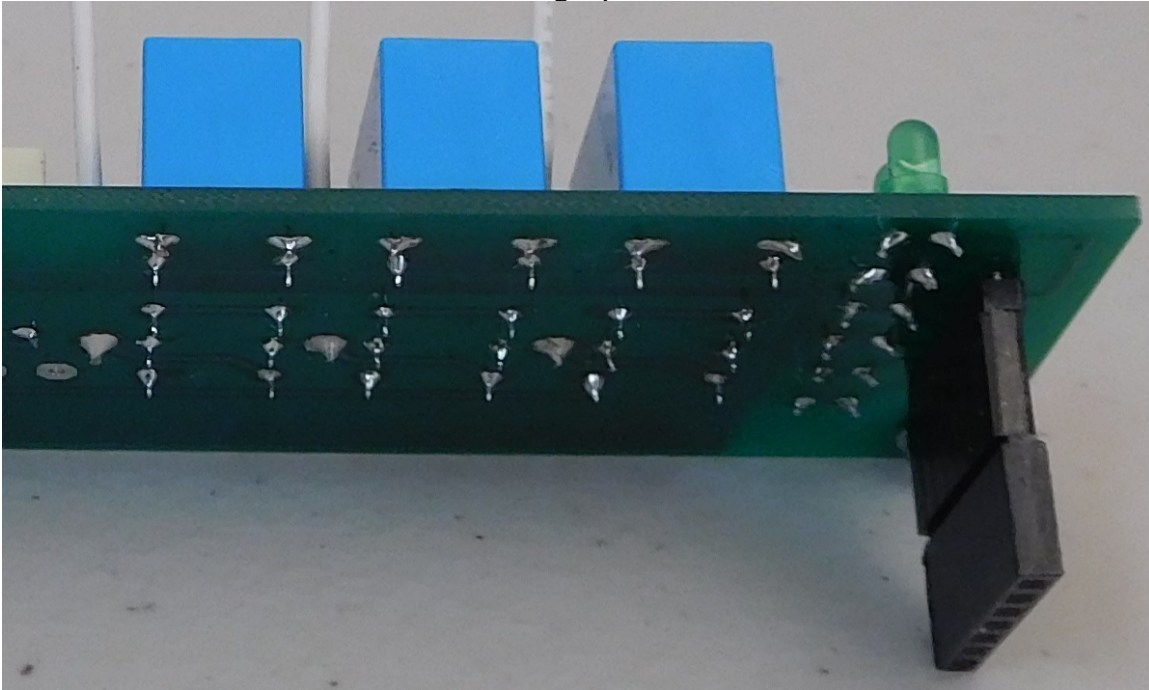

Figure 5-showing connector installed into the left channel PCB

Install the mounting brackets

Fasten two brackets to the mounting holes using the provided 4-40x1/4" sems screws as shown below. The brackets are almost symmetric, so you'll have to inspect them carefully to install them with the correct orientation.



Figure 6-Bracket installation detail

Building the Right Channel PCB

The bare PCB for the right channel is shown in Figure 7.

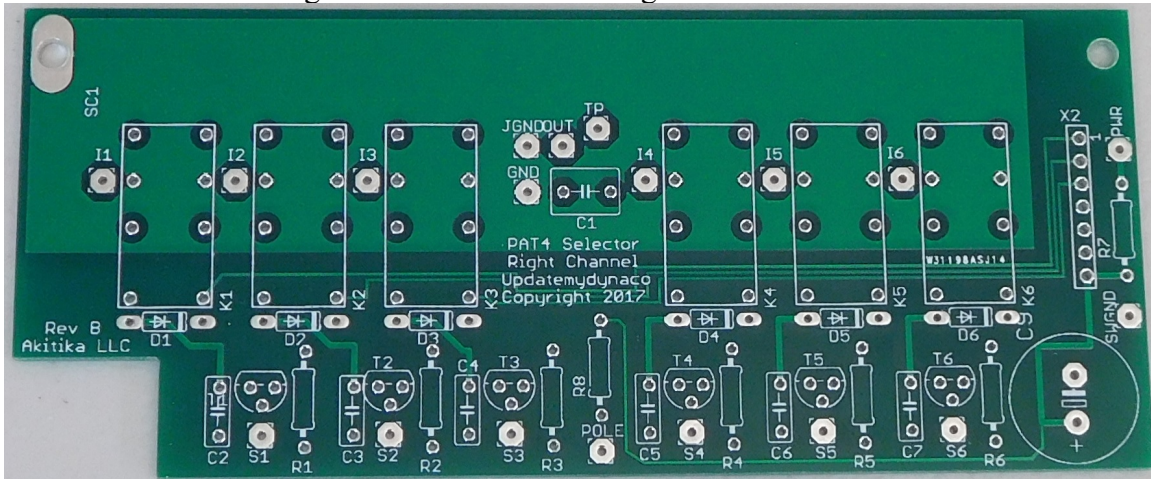
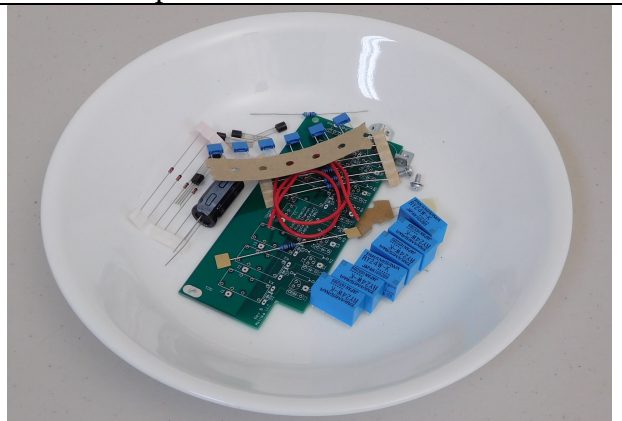

Figure 7-Component side of the right channel PCB before loading

Begin by carefully emptying the contents of the right channel parts envelope into a broad soup bowl, as shown below. In general, you'll start with the components that lay closest to the board, working your way towards the taller components. You will:

1. Install the diodes
2. Install the resistors
3. Install the relays
4. Install the transistors
5. Install the film capacitors
6. Install the signal wires
7. Install the large electrolytic capacitor
8. Install the brackets and connector



Install the Diodes

Track your progress by placing a checkmark in the done column as you install each diode. The diode leads are spaced at 0.3". If you have a lead bender, this will speed up and neaten your assembly. A lead bender is not required.

Note: Diodes are polarized. Make sure that the banded end of the diode is matched with the band on the silk-screen.

Desig	Type	Marking	Done <input checked="" type="checkbox"/>
D1	1N4148, switching diode	4148	<input type="checkbox"/>
D2	1N4148, switching diode	4148	<input type="checkbox"/>
D3	1N4148, switching diode	4148	<input type="checkbox"/>
D4	1N4148, switching diode	4148	<input type="checkbox"/>
D5	1N4148, switching diode	4148	<input type="checkbox"/>
D6	1N4148, switching diode	4148	<input type="checkbox"/>

Install the resistors

Before you install the resistors, we recommend checking them both by color code and with a meter. As Norm Abrams of “This Old House” would say, “measure twice cut once”.

Desig	Value	Marking	Done☑
R1	10K0	Brown, black, black, red, brown	<input type="checkbox"/>
R2	10K0	Brown, black, black, red, brown	<input type="checkbox"/>
R3	10K0	Brown, black, black, red, brown	<input type="checkbox"/>
R4	10K0	Brown, black, black, red, brown	<input type="checkbox"/>
R5	10K0	Brown, black, black, red, brown	<input type="checkbox"/>
R6	10K0	Brown, black, black, red, brown	<input type="checkbox"/>
R7	499	Yellow, white, white, black, brown	<input type="checkbox"/>
R8	100K	Brown, black, black, orange, brown	<input type="checkbox"/>

Install the Relays

Install the relays, making sure that they sit flat on the PCB. Here’s a hint about how to do this:

1. Solder just two corner pins at first. Inspect the result to make sure that:
 - a. the relay is sitting flat on the board, and
 - b. All the relay pins are protruding through their holes in the PCB
2. Given that just two joints have been done at this point, it’s easy to reheat one or both and adjust the relay as needed.
3. When everything looks good, solder the rest of the relay pins.
4. Inspect your work to make sure that every pin has been soldered.

Desig	Value	Done☑
K1	24-volt coil, DPDT	<input type="checkbox"/>
K2	24-volt coil, DPDT	<input type="checkbox"/>
K3	24-volt coil, DPDT	<input type="checkbox"/>
K4	24-volt coil, DPDT	<input type="checkbox"/>
K5	24-volt coil, DPDT	<input type="checkbox"/>
K6	24-volt coil, DPDT	<input type="checkbox"/>

Install the Transistors

Install the transistors so that the top of the transistor body is about even with the tops of the relays. Make sure that the shape of the transistor package matches the shape of the silk-screen outline.

Desig	Value	Done☑
T1	2N5551, 150-volt NPN	<input type="checkbox"/>
T2	2N5551, 150-volt NPN	<input type="checkbox"/>
T3	2N5551, 150-volt NPN	<input type="checkbox"/>
T4	2N5551, 150-volt NPN	<input type="checkbox"/>
T5	2N5551, 150-volt NPN	<input type="checkbox"/>
T6	2N5551, 150-volt NPN	<input type="checkbox"/>

Install the Capacitors

The PAT4SEL also replaces the original electrolytic capacitor that coupled signals to the tape recorder input with a 1 uF film cap. Install that capacitor now.

Desig	Value	Marking	Done <input checked="" type="checkbox"/>
C1	1 μ F, 63V film	1J63	<input type="checkbox"/>
C2	0.01 μ F, 100V film	10nJ100	<input type="checkbox"/>
C3	0.01 μ F, 100V film	10nJ100	<input type="checkbox"/>
C4	0.01 μ F, 100V film	10nJ100	<input type="checkbox"/>
C5	0.01 μ F, 100V film	10nJ100	<input type="checkbox"/>
C6	0.01 μ F, 100V film	10nJ100	<input type="checkbox"/>
C7	0.01 μ F, 100V film	10nJ100	<input type="checkbox"/>

Install the RCA Signal Wires

Prepare 5 pieces of red 22 AWG wire as shown here:

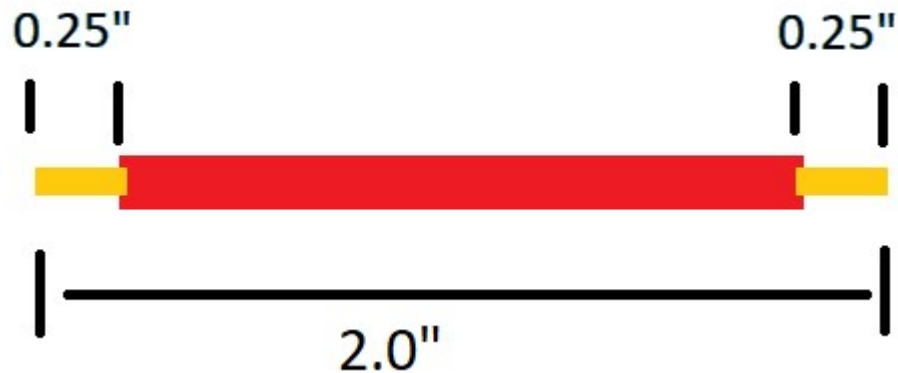

Figure 8-Right channel signal wire preparation

Install one of each of these wires from the component side of the board, and solder them on the solder side of the board. Don't install into I1, as that will be done later.

Desig	Value	Done <input checked="" type="checkbox"/>
I2	Red wire	<input type="checkbox"/>
I3	Red wire	<input type="checkbox"/>
I4	Red wire	<input type="checkbox"/>
I5	Red wire	<input type="checkbox"/>
I6	Red wire	<input type="checkbox"/>

Prepare one 4.5" long piece of red 22 AWG solid wire. Strip 1/4" of insulation from both ends. Insert one end of the wire into the TP eyelet from the component side of the board. Solder it on the solder side.

Install the electrolytic capacitor

Be careful. Electrolytic capacitors are polarized, so the orientation is important. As you look at the silk screen, you'll see that the negative lead of the capacitor installs in the hole closest to the center of the PCB.

Desig	Value	Marking	Done <input checked="" type="checkbox"/>
C9	470 μ F, 63 Volt electrolytic	470 μ F	<input type="checkbox"/>

Install the connector

Install the connector from the component side of the board and solder it on the solder side. Refer to the following picture before you solder.

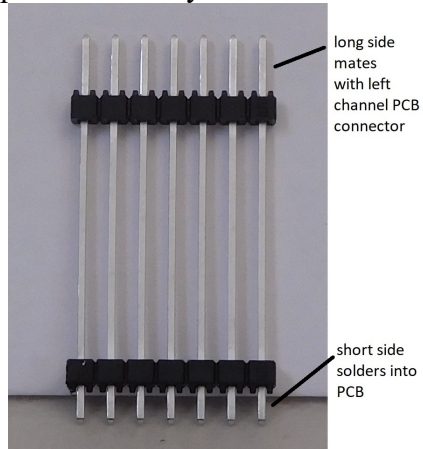

Figure 9-Short side of connector solders into the PCB

1. Make sure that the short side pins are installed into the PCB.
2. Make sure the connector sits flat on the board, with its body perpendicular to the plane of the board. Solder just one end pin first, then re-check.
3. Re-heat and adjust as needed. Now, solder the other end pin, and re-check that the connector is sitting flat on the board, and is perpendicular to the board. When all that looks ok, solder the remaining 5 pins.

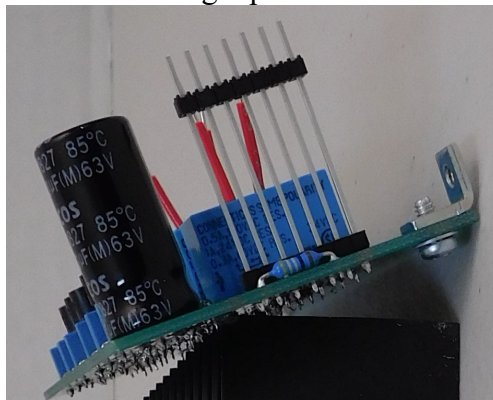

Figure 10-Showing the connector installed into the right channel PCB

Install the mounting brackets

Fasten two brackets to the mounting holes using the provided 4-40x1/4" sems screws as shown below. The brackets are almost symmetric, so you'll have to inspect them carefully to install them with the correct orientation.



Figure 11-Bracket installation detail

Remove the cover

Disconnect your PAT-4 from your music system. In particular, make sure the AC plug is not plugged in.

IMPORTANT – Make sure that the AC plug is not plugged in!

1. Remove two screws from the left side of the cover.
2. Remove two screws from the right side of the cover.
3. Some later PAT-4's may have a sheet metal screw in the back of the cover along the back panel. If so, also remove this screw.
4. Lift the cover off your PAT-4 and set it aside.
5. Loosen the set screw in each of the knobs and remove the knobs.
6. Some of the controls will have nuts that retain the front panel. Remove those nuts, then remove the front panel. Set it aside in a safe place.

Overview of selector switch connections

Let's take a minute to give an overview of the new selector switch architecture:

- It has six inputs high-level inputs: Special, Tape Head, Phono, Tape, Tuner, and Spare
 - The phono preamp is permanently configured for phono equalization and connected to the PHONO LOW inputs. Its output connects to the I1 inputs.
 - The net effect is 1 phono input and 5 high-level inputs.
- It has two outputs:
 - OUT connects through the Tape Monitor switch to the volume control.
 - TP connects to the TO TAPE Outputs
- As before, the TAPE AMP inputs connect to both the Tape Monitor switch and to I4 of the new selector PCBs.

Get your phono section ready for the new selector switch

You may have 4 different types of phono section in your PAT-4 preamp:

1. PAT4PPR – the PAT4 Preamp Phono stage replacement
2. PAT4LP – the original PAT4 preamp as upgraded with the PAT4LP kit
3. The original PAT4 phono preamp
4. The PAT4RENEW phono stage.

In each of these cases, we will:

- Hard-wire the inputs directly to the PHONO LOW RCA jacks
- Hard-wire the outputs to the I1 terminals on the new selector switch boards.

The following sub-sections details how this is done.

PAT4PPR

If you have the PAT4PPR phono preamp. You are already nearly done. As part of the standard installation:

- its input was previously hard-wired to the PHONO LOW RCA jacks, so no change is needed for the input wires.
- Its output went to the old selector switch. Cut the wires from the outputs of the PAT4PPR near to the old selector switch. The free ends will later connect to I1 of the selector switch PCBs.

PAT4LP

If your PAT4LP was installed to provide 1 phono and 5 high level inputs, as shown in the schematic of Figure 11 of the PAT4 Phono Upgrade manual then:

- No change is needed for the input wires as they already go directly to the phono preamp input on pins 1 and 2 of PC-16 boards.

If your PAT4LP was installed to provide 3 phonos and 3 high level inputs, as shown in the schematic of Figure 10 of the PAT4 Phono Upgrade manual then:

- You will instead directly wire the PHONO LOW RCA jacks to pins 1 and 2 of the PC16's using shielded cable. Refer to "Appendix 2 - Preparing a Shielded Cable End" for more detail. 18" of shielded cable is included in the kit.
 - Connect pin 1 to the center conductor.
 - Connect pin 2 to the shield.

In either case, its output went to the old selector switch. Cut the wires from pin 5 of PC-16 near where it attaches to the selector switch. Do this for both the left and right channel. The free ends will later connect to I1 of the selector switch PCBs.

PAT4 Original Phono Preamp

Please note that this arrangement will have a click, just like the original did, when switching in and out of the phono position.

- Wire directly from the PHONO LOW RCA jacks to pins 1 (signal) and 2 (ground) of the PC-16 PCBs. Do this for both the left and right channels.
- Run a jumper from eyelet 5 to eyelet 6 for both the right and left channel PCBs.

- Cut the wires from pin 5 of PC-16 near where it attaches to the selector switch. Do this for both the left and right channel. The free ends will later connect to I1 of the selector switch PCBs.

PAT4Renew Phono Preamp

The PAT4RENEW board has renewed line stage and phono preamp. As part of the standard installation of the PAT4RENEW kit:

- its input was previously hard-wired to the PHONO LOW RCA jacks with shielded cable run from pins 1 (signal) and 2 (ground) of the PAT4RENEW board, so no change is needed for the input wires.
- The PAT4RENEW's phono preamp outputs appear on eyelet 5 of the PAT4RENEW PCB. The Pin 5 outputs (Left and Right) were connected to the old selector switch. Cut the wires from the Pin 5 phono preamp outputs of the PAT4RENEW near to the old selector switch. The free ends will later connect to I1 of the selector switch PCBs.

Modify two selector switch connections

Before you remove the old selector switch, you'll need to modify these two wires:

1. Identify the wire from the TAPE AMP RIGHT RCA jack center conductor. Follow it to the old selector switch, terminal 9 of the front deck. Disconnect both wires that connect to this terminal. (The second wire goes to terminal 3 of the tape monitor switch).
 - a. Slide a piece of heat shrink tubing over the wire that goes to the back panel. Slide it about 6" away from the cut end.
 - b. Twist the two wires together and solder them.
 - c. Slide the heat-shrink tubing over the wires, and use the barrel of the soldering iron to shrink the heat-shrink tubing.
 - d. The result connects the TAPE AMP RIGHT RCA jack to the right channel, tape monitor position of the tape monitor switch.
2. Identify the wire from the TAPE AMP LEFT RCA jack center conductor. Follow it to the old selector switch, terminal 9 of the rear deck. Disconnect both wires that connect to this terminal. (The second wire goes to terminal 6 of the tape monitor switch).
 - a. Slide a piece of heat shrink tubing over the wire that goes to the back panel. Slide it about 6" away from the cut end.
 - b. Twist the two wires together and solder them.
 - c. Slide the heat-shrink tubing over the wires, and use the barrel of the soldering iron to shrink the heat-shrink tubing.
 - d. The result connects the TAPE AMP LEFT RCA jack to the left channel, tape monitor position of the tape monitor switch.

Identify two remaining wires to the tape monitor switch

It may be helpful to refer to Figure 17-Front Panel Wiring on page 25 to identify these wires:

1. Identify the wire that comes from pin 1 of the tape monitor switch (MS) that goes to pin 12 of the front deck of the selector switch. Disconnect this wire where it

- connects to the selector switch. Label this wire RIGHT OUT. In a later step, you will connect it to the OUT eyelet of the RIGHT channel selector PCB, but once you've labeled the wire, please move on.
2. Identify the wire that comes from pin 4 of the tape monitor switch (MS) that goes to pin 12 of the rear deck of the selector switch. Disconnect this wire where it connects to the selector switch. Label this wire LEFT OUT. In a later step, you will connect it to the OUT eyelet of the LEFT channel selector PCB, but once you've labeled the wire, please move on.

Remove the Original selector switch

1. Remove the nut that holds the selector switch into the front panel.
2. Cut or de-solder all the original switch wires that went between the “hot” connections of the RCA jacks and the selector switch.
3. Depending upon what modifications you have previously installed, there will be a few other wires between the selector switch and the preamp PCBs. Cut those wires near where they enter the preamp PCBs.

Installing the PCBs in your PAT-4 Preamp

The following discussion may be helped by referring to Figure 16.

Pre-wiring the Right Channel PCB

Pre-wire the right channel (bottom PCB with the cut-out):

1. Cut an 11” length of the supplied red/black 22 AWG twisted pair. Strip ¼” of insulation from all 4 ends.
2. From one end of the twisted pair:
 - a. Insert the red wire into the component side of the terminal labeled PWR and solder it on the solder side.
 - b. Insert the black wire into the component side of the terminal labeled SWGND and solder it on the solder side.
3. Prepare the multi-conductor cable by cutting it to an overall length of 10”. Then:
 - a. Remove 1.5” of the gray jacket from one side.
 - b. Remove 2.5” of the gray jacket from the other side.
4. Working with the 2.5” side of the multi-conductor cable, remove ¼” of insulation from each wire, then twist and tin the strands before inserting them. Insert the wire from the solder side, and solder it on the component side, as follows:
 - a. Brown wire into S1
 - b. Red wire into S2
 - c. Orange wire into S3
 - d. Yellow wire into S4
 - e. Green wire into S5
 - f. Blue wire into S6
 - g. Violet wire into POLE
 - h. Note that the following wire colors will not be connected and should be either taped back or cut:
 - i. Black
 - ii. Gray
 - iii. Bare drain wire
5. Working with the 1.5” side of the multi-conductor cable, connect the following wire colors to the selector switch terminals as shown below. Note that these wires will be in a different order when connected to the switch so that the marking on the RCA jacks follows the indications on the selector switch while also allowing the shortest wires between the RCA jacks and the relays:
 - a. Switch terminal 1 to the RED wire
 - b. Switch terminal 2 to the ORANGE wire

- c. Switch terminal 3 to the BROWN wire
- d. Switch terminal 4 to the YELLOW wire
- e. Switch terminal 5 to the GREEN wire
- f. Switch terminal 6 to the BLUE wire
- g. Switch POLE terminal to the VIOLET wire.
- h. Note that the following wire colors will not be connected and should be either taped back or cut:
 - i. Black
 - ii. Gray
 - iii. Bare drain wire

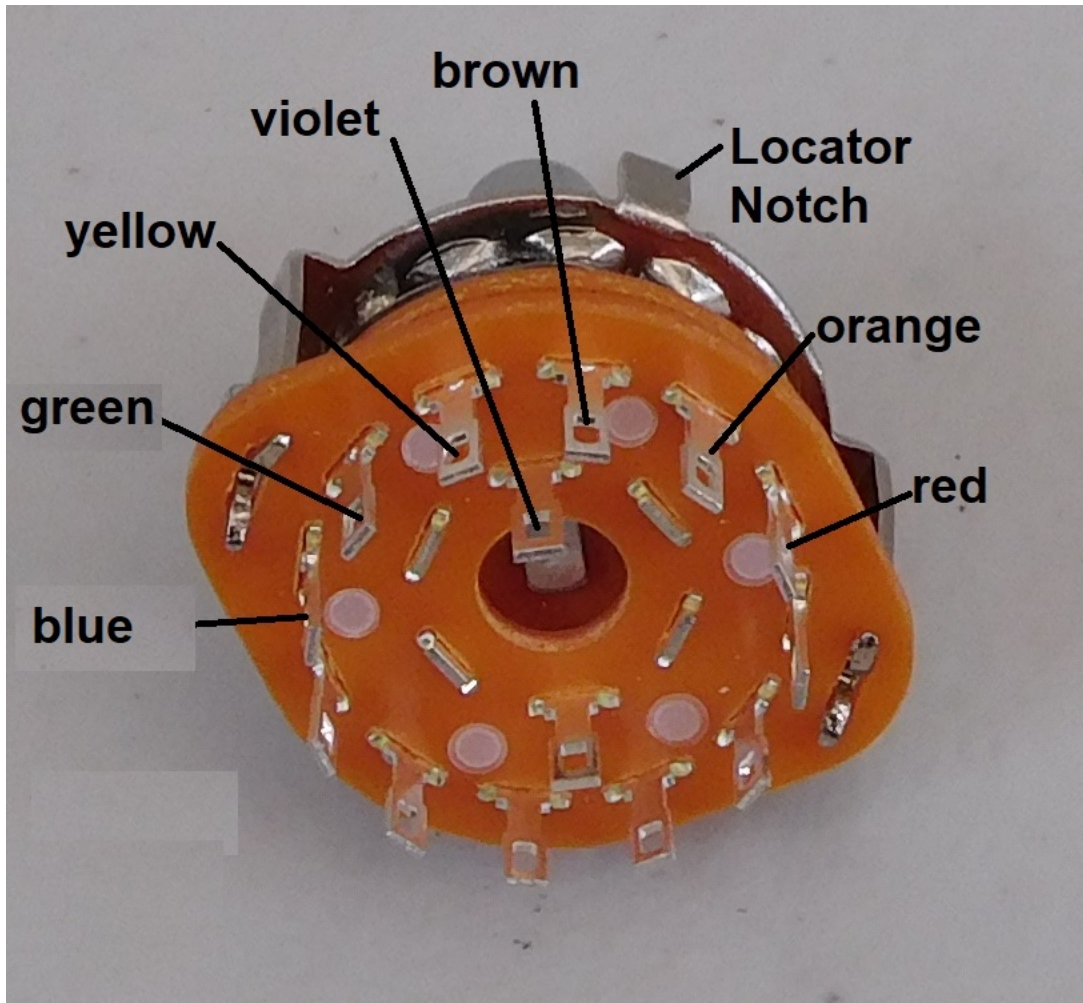

Figure 12-wired selector switch

Figure 13-Wiring the new selector switch, alternate view

Installing the Right Channel PCB

It's typically easier to complete this section by removing the 4 screws (two along each side of the chassis bottom) that hold the back panel in place. After that, wiggle the back panel, and it will come loose. Be careful not to put too much strain on the wires between the back panel and the main chassis of the preamp.

1. There is a foot that sits under the right channel PCB. If it is held in by rivets, you may skip this step. If it is held in by screws, that screw (1/2" length) is probably too long and will interfere with the right channel PCB. Replace that screw with the supplied 3/8" screw. Please note that you'll have to push the old screw out of the old foot, and push the new screw into the foot.
2. Remove the old 1 mfd tape monitor cap, refer to Figure 16. If it's easy, remove the terminal strip that held the capacitor.
3. Connect the red wire from the TP eyelet to the center conductor of the RIGHT channel "TO TAPE" RCA jack.
4. Connect the wire you labeled RIGHT OUT in the section "Identify two remaining wires to the tape monitor switch" to the OUT eyelet on the right channel PCB. If the wire happens to be a little short, you can splice it using some of the supplied 22 AWG red wire and heat-shrink tubing.
5. Connect the phono section output to the I1 eyelet, inserting it from the component side and soldering it on the solder side.
6. Install the right channel PCB into the back-panel.
 - a. Remove the bottom two 4-40 screws and nuts.
 - b. Re-use the two 4-40 screws as you install the PCB. Those screws will engage the mounting brackets for the PCB's.
7. For the right channel PCB, connect the wires to the 5 RCA jacks.
 - a. The wire from I2 connects to the right channel RCA SPECIAL center conductor.
 - b. The wire from I3 connects to the right channel RCA TAPE HEAD center conductor.
 - c. The wire from I4 connects to the right channel RCA TAPE AMP center conductor. Note that there will already be a wire on this terminal (it runs to the Tape Monitor switch).
 - d. The wire from I5 connects to the right channel RCA TUNER center conductor.
 - e. The wire from I6 connects to the right channel RCA SPARE center conductor.
8. **If your PAT4PWR is REVB, then follow these directions. If it is REVC, then skip to item 9.** Connect the red/black twisted pair from PWR and SWGND to the PAT4PWR PCB.
 - a. Run the red/black twisted pair along the floor of the chassis toward the PAT4PWR PCB.
 - b. Solder the black wire to the open CT terminal.
 - c. Solder the red wire to D8's cathode. Place a small J-hook in the end of the red wire, and loop it around D8's cathode. Tighten it with needle nose pliers, and solder it carefully.
9. **If your PAT4PWR is REVC, then follow these directions.** Connect the red/black twisted pair from PWR and SWGND to the PAT4PWR PCB. Insert the wires from the solder side, and solder them on the component side.
 - a. Run the red/black twisted pair along the floor of the chassis toward the PAT4PWR PCB.

- b. Solder the black wire to an open CT terminal, either CT or CT1, whichever is available.
- c. Solder the red wire to VRAW1 or VRAW2, whichever is available.

Make sure that there is clearance between the bottom of the right channel PCB and the mounting screw for the back left-corner foot. Check these details to get clearance:

- 10. Note in direction one at the top of this page, it says to use a 3/8" screw.
- 11. Re-check Figure 11 for the correct orientation of the mounting brackets.
- 12. If all else fails, put a bit of packing tape on the bottom of the PCB to keep the mounting screw from touching the PCB traces.
- 13. Failure to maintain clearance may keep the right channel phono from working.

Note that the picture below shows installation with a PAT4PWR REV B.

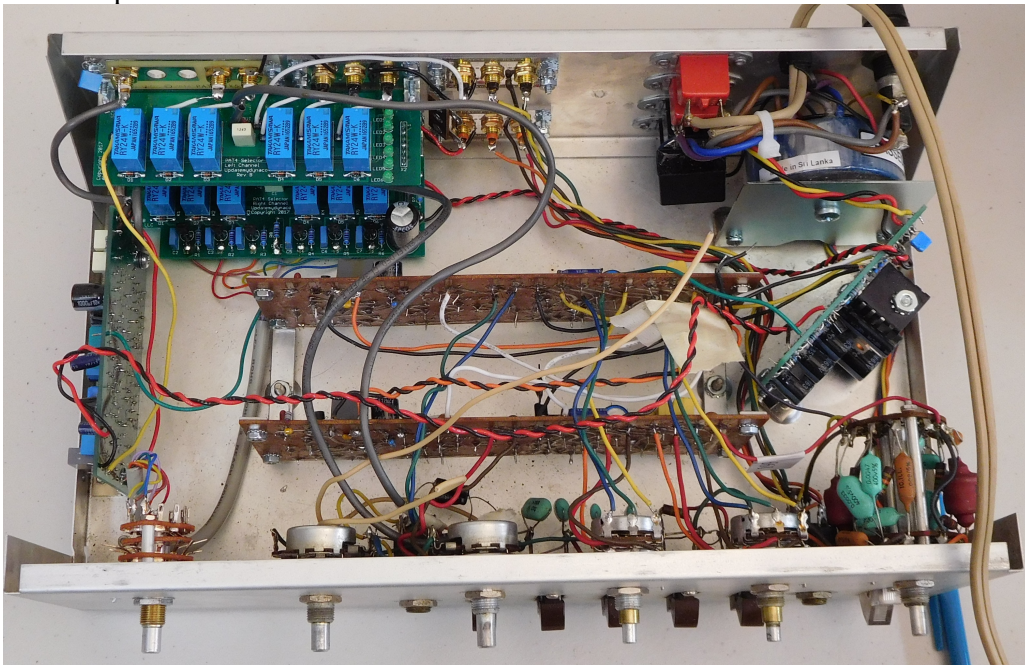

Figure 14-Preliminary look at installed selector replacement

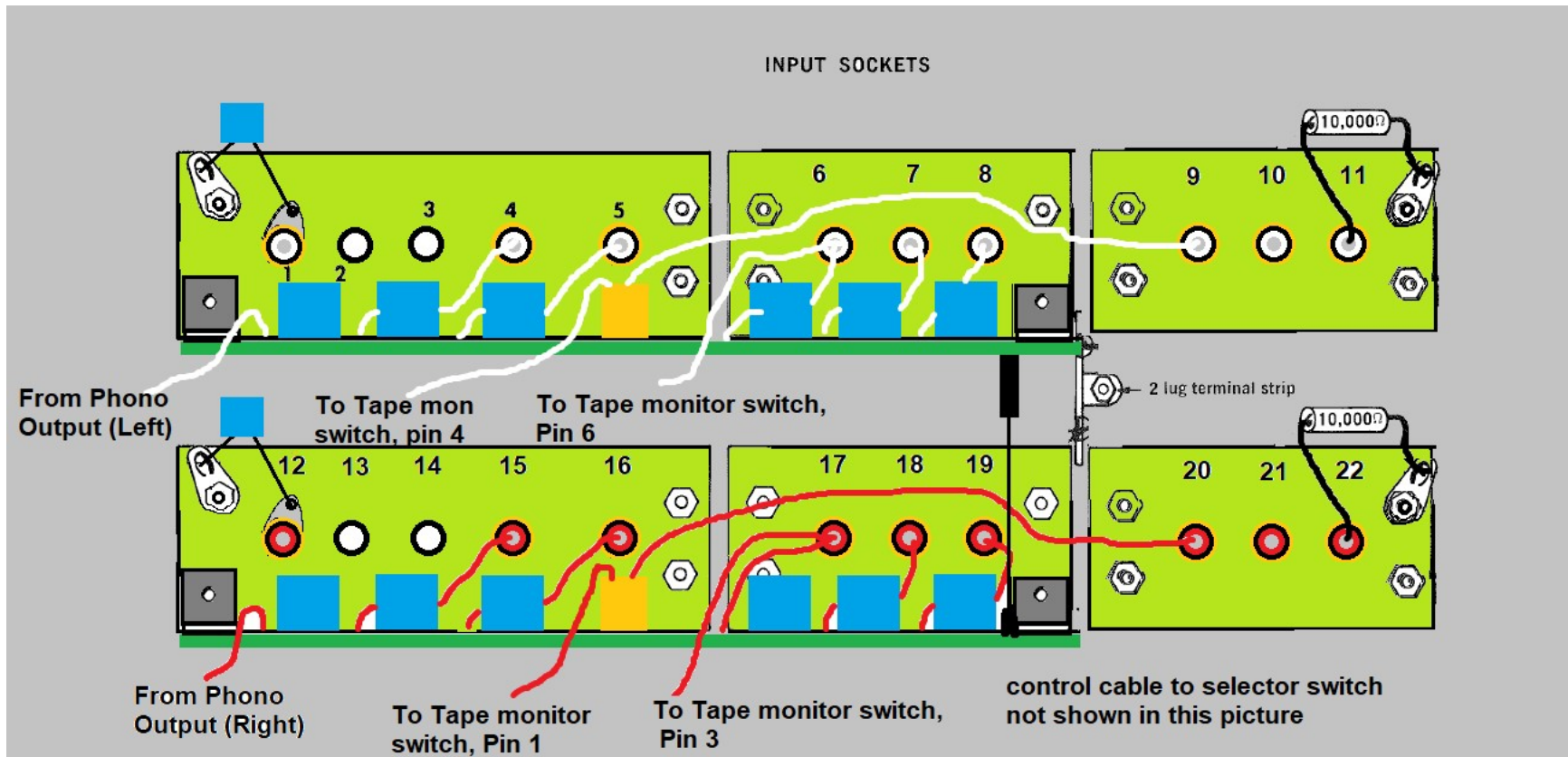

Figure 15-Wiring the new jack arrangement (some wires not show to avoid clutter)

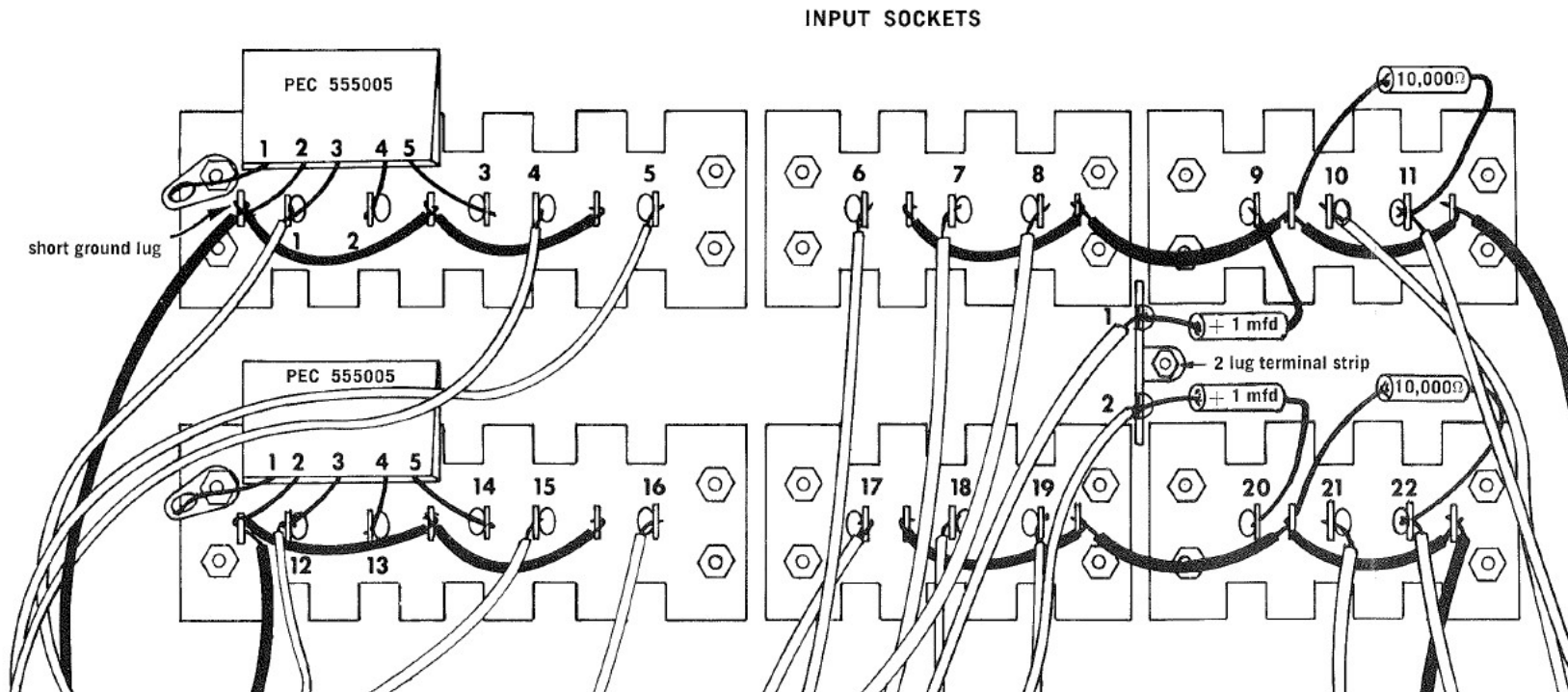

Figure 16-Original Back Panel Wiring, 1 mfd caps get removed and replaced by caps on the new selector PCBs

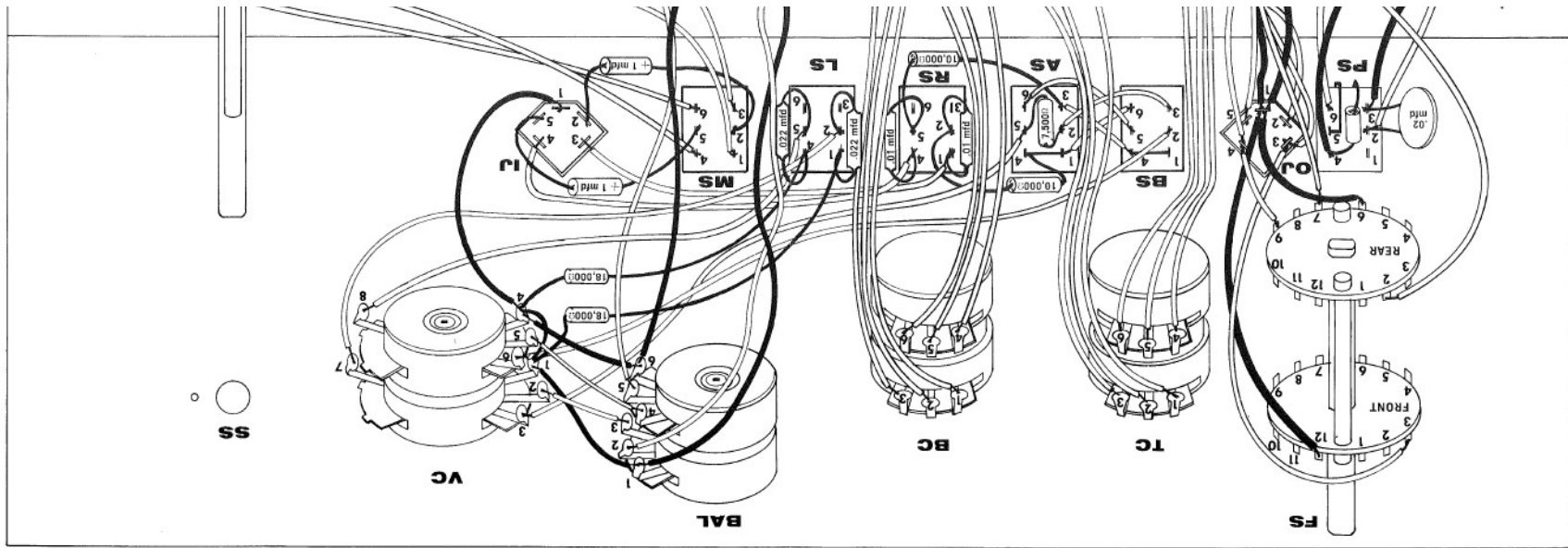

Figure 17-Front Panel Wiring

Installing the Left Channel PCB

1. Remove the old tape monitor cap. If it's easy, remove the terminal strip that held the capacitor.
2. Connect the white wire from the TP eyelet to the center conductor of the LEFT channel "TO TAPE" RCA jack. If it isn't already removed, remove the 1 mfd cap and terminal strip that used to connect to the TO TAPE RCA jack.
3. Connect the wire you labeled LEFT OUT in the section "Identify two remaining wires to the tape monitor switch" to the OUT eyelet on the left channel PCB. If the wire happens to be a little short, you can splice it using some of the supplied 22 AWG white wire and heat-shrink tubing.
4. Connect the left channel phono section output to the I1 eyelet, inserting it from the component side and soldering it on the solder side.
5. Install the left channel PCB into the back-panel.
 - a. Remove the bottom two 4-40 screws and nuts (refer to Figure 16).
 - b. Mate the top and bottom board connectors as you set the top PCB into place.
 - c. Re-use the two 4-40 screws as you install the PCB. Those screws will engage the mounting brackets for the PCB's.
6. For the right channel PCB, connect the wires to the 5 RCA jacks.
 - a. The wire from I2 connects to the left channel RCA SPECIAL center conductor.
 - b. The wire from I3 connects to the left channel RCA TAPE HEAD center conductor.
 - c. The wire from I4 connects to the left channel RCA TAPE AMP center conductor. Note that there will already be a wire on this terminal (it runs to the tape monitor switch).
 - d. The wire from I5 connects to the left channel RCA TUNER center conductor.
 - e. The wire from I6 connects to the left channel RCA SPARE center conductor.

Re-assemble your pre-amp and pre-test your work

If you removed the 4 screws that hold the back panel to the chassis floor, re-install them now. Make sure that no wires are pinched or hanging loose as you reattach the back panel.

Temporarily re-attach the selector knob to the selector switch and tighten the set-screw. Rotate the new selector switch fully counter-clockwise, to the SPECIAL position.

You'll now plug the AC power cord in and turn on the PAT-4 power switch. Re-check your 38-volt supply on the PAT-4 power to make sure it is still in spec.

Be careful – stay away from the 120 or 240 volts AC now present in the PAT-4

Check that:

1. LED2 lights when the selector is set to SPECIAL
2. LED3 lights when the selector is set to TAPE HEAD

3. LED1 lights when the selector is set to PHONO
4. LED4 lights when the selector is set to TAPE
5. LED5 lights when the selector is set to TUNER
6. LED6 lights when the selector is set to SPARE

Re-assemble your preamp as follows:

1. Pull the power cord from the wall outlet.
2. Remove the temporarily installed selector knob.
3. Replace the front panel and fasten it in place using the same nuts that previously held it on.
4. Re-install and align the knobs.
5. Replace the cover.
6. Re-install the 4 (or 5) screws that hold the top cover in place.

You're now ready to re-install your PAT-4 preamp into your music system.

Schematics

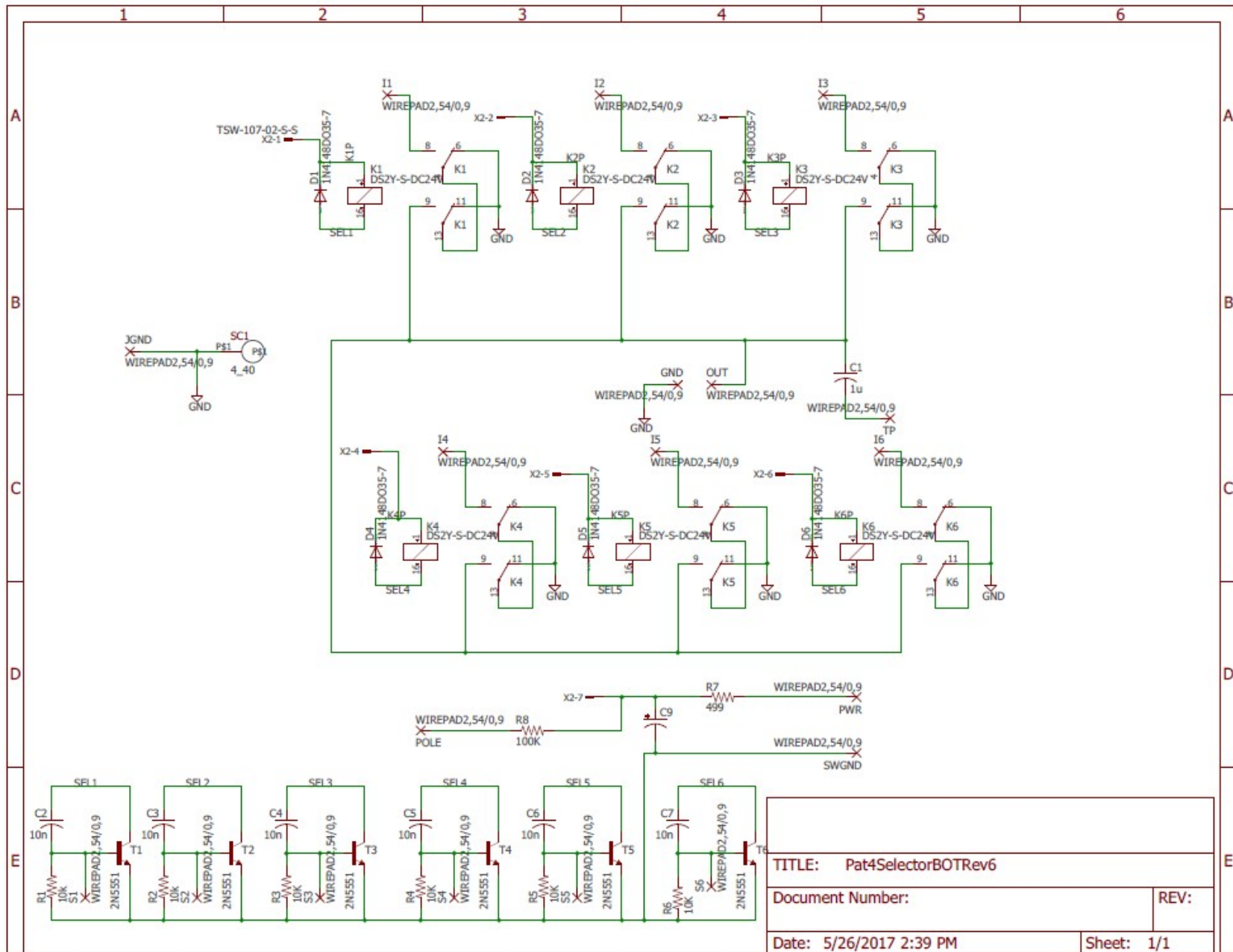

Figure 18-Right channel selector board schematics
Page 28 of 33

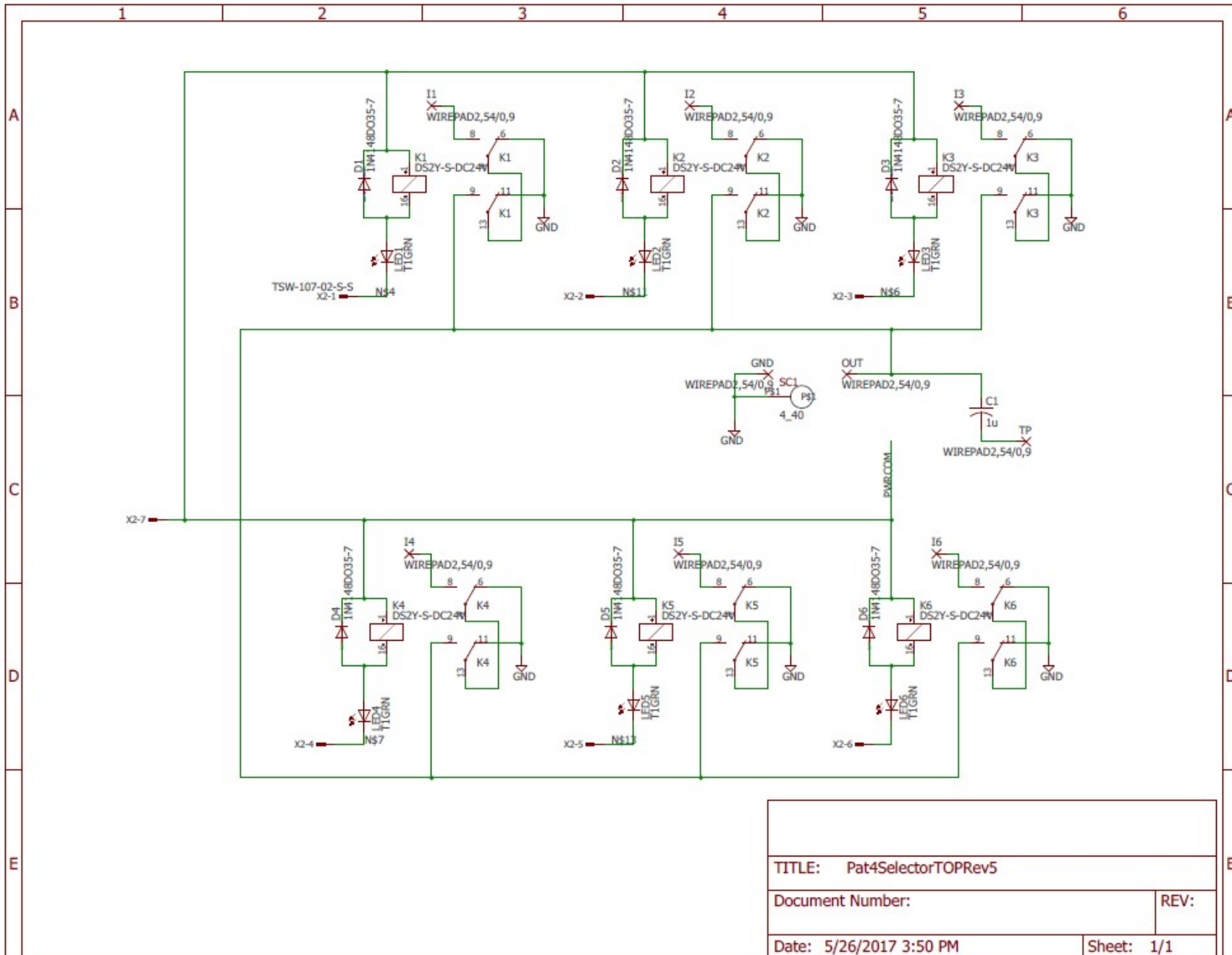

Figure 19-Schematic of left channel circuit board

Appendix 1: The Toothpick Trick

This appendix describes an easy way to clear the solder from a hole in the PCB. It can also be used to clear the solder from terminals on pots or jacks. Doing so makes it easier to install a new component, or reinstall wires that were temporarily removed to allow access to some other component.

All you'll need is a soldering iron and some toothpicks with sharp points. The diameter of the pointed part of the toothpick must be smaller than the diameter of the hole that you're trying to clear.

Heat the solder land on the component side of the board until the solder flows. Insert the toothpick from the component side of the board while pushing and twisting the toothpick. If the solder has melted, the toothpick should push through the board, displacing the solder. Remove the soldering iron, but let the toothpick remain in the hole until the solder has solidified. Now remove the toothpick. There should be a hole through the solder sufficiently large to allow you to insert the component lead or wire.

Sometimes, a bit of the toothpick will break off in the hole. If this happens, use a stiff piece of wire to push the toothpick fragment out of the hole.

Appendix 2 - Preparing a Shielded Cable End

This section tells how to prepare the ends of the shielded cable. This process will be repeated four times, at both ends of both input cables (although the cables will have different overall lengths).

1. Cut the shielded cable to the overall required length.



2. Use a utility knife with a new, sharp blade to cut the plastic jacket of the shielded cable 3/4" back from the end. Hold the blade perpendicular to the cable, and draw it across the cable lightly as you rotate the cable along its long dimension. This creates a scored line through the plastic jacket. With a sharp blade, not much pressure is needed. You may need a bit of practice to get the feel.



3. If you've scored the jacket carefully, you can separate the jacket at the score line without using tools. Pull the insulating jacket off, exposing the cable, showing the foil shield, the drain wire, and the fuzzy string. The result is shown here, with the foil shield showing.



4. Cut off the fuzzy string.



5. Separate and twist the drain wire.



6. Peel back and remove the foil. Remove the plastic wrap from the red and black wires. The drain (bare wire), red, and black wires are exposed now that gray insulating jacket, foil shield, and plastic over-wrap have been removed.
7. To make a shielded cable for a right channel application, pull the black wire out of the shielded cable and leave the red wire for RIGHT channel signals.
8. To make a shielded cable for a LEFT channel application, pull the red wire out of the shielded cable and leave the black wire for LEFT channel signals.
9. Remove 1/4" of insulation from the red wire. Twist its strands tightly. Twist and tin the ends of the red wire (or black wire if preparing a left channel input cable) and the drain wire.
10. Slip about half of the gray outer jacket you removed in the first step over the drain wire. This will keep the bare drain wire from contacting something by accident.

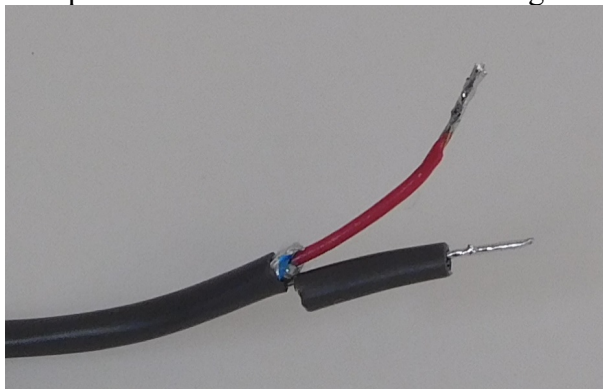

Figure 20- Shield wire end prep completed (right channel)

Appendix 3 - Resistor Color Code



Figure 21-demonstrating the resistor color code

Here's an extreme close-up of a ¼ W metal film 20K (20,000) Ohm resistor, designated by the standard resistor color code.

The colors map to numbers:

Color	Number
Black	0
Brown	1
Red	2
Orange	3
Yellow	4
Green	5
Blue	6
Violet	7
Gray	8
White	9

The color band positions have the following meaning:

Position	Meaning
1	Left-most Digit (e.g. most significant)
2	Next digit to the right
3	Next digit to the right.
4	Number of zeros that follow the three digits, unless: <ul style="list-style-type: none"> • Band 4 is gold => multiply by 0.1 • Band 4 is silver=> multiply by 0.01
5	Tolerance: <ul style="list-style-type: none"> • Violet => 0.1% • Brown =>1% • Red => 2% • Gold=> 5% • Silver=>10%